

---

# Table of Contents

## N55 Engine

<b>Subject</b>	<b>Page</b>
<b>Introduction</b> .....	<b>5</b>
Engine Designation and Engine Identification .....	6
Engine Designation .....	6
Breakdown of N55 Engine Designation .....	7
Engine Identification .....	7
<b>Engine Mechanical</b> .....	<b>9</b>
Engine Housing .....	9
Engine Block .....	9
Crankcase and Bedplate .....	9
Crankshaft .....	12
Crankshaft Main Bearings .....	12
Pistons and Rings .....	13
Connecting Rod and Bearings .....	14
Oil Pan .....	18
Electronic Volume-controlled Oil Pump .....	19
Oil Pump and Pressure Control .....	20
Oil Supply .....	24
Oil Filtration and Oil Cooling .....	27
Oil Spray Nozzles .....	28
Oil Pressure .....	28
Oil Level .....	28
Oil Return .....	28
Cylinder Head .....	29
Cylinder Head Cover .....	30
Crankcase Ventilation .....	31
Naturally Aspirated Mode .....	31
Boost Mode .....	33
Valvetrain .....	36
Intake and Exhaust Valves .....	37
Valve Springs .....	37
Camshafts .....	38
Valve Timing .....	39
VANOS System .....	40
Overview .....	41
VANOS Solenoid Valves .....	42

<b>Subject</b>	<b>Page</b>
Cam Sensor Wheels .....	42
VALVETRONIC III .....	43
Phasing .....	43
Masking .....	43
Combustion Chamber Geometry .....	46
Valve Lift Adjustment Overview .....	47
VALVETRONIC Servomotor .....	49
Function .....	49
Belt Drive and Auxiliary Components .....	50
Vibration Damper .....	51
<b>Air Intake and Exhaust System .....</b>	<b>53</b>
Air Intake System .....	53
Intake Manifold .....	56
Fuel Tank Ventilation System .....	57
Exhaust Manifold .....	58
Turbocharger .....	59
Function of the Twin Scroll Turbocharger .....	60
Diverter Valve .....	60
Catalytic Converter .....	61
Exhaust System .....	62
Vacuum System .....	63
Vacuum Pump .....	64
<b>Fuel System .....</b>	<b>66</b>
Fuel Injection .....	66
Fuel Pressure Sensor .....	67
High Pressure Fuel Pump .....	68
Fuel Injectors .....	69
<b>Cooling System .....</b>	<b>70</b>
Components .....	72
N55, Cooling System Components .....	72
Oil Cooler .....	74
Coolant Passages .....	75
<b>Service Information .....</b>	<b>77</b>
Cylinder Head .....	77
Cylinder Head Cover .....	77
Fuel Injectors .....	77
Ignition Coils .....	78

**BLANK  
PAGE**

---

# N55 Engine

**Model: All with N55**

**Production: From Start of Production**

# OBJECTIVES

After completion of this module you will be able to:

- Describe the features of the N55B30M0 engine
- Describe the specifications of the N55 engine
- Identify the internal and external components of the N55 engine
- Understand the function of the crankcase ventilation on the N55 engine
- Understand the function of the electronic volume control oil pump

# Introduction

The N55 engine is the successor to the N54. Re-engineering and modifications have made it possible to now use only one exhaust turbocharger. Against the backdrop of reduced costs and improved quality, the technical data have remained virtually the same.

## N55 Engine



# Engine Designation and Engine Identification

## Engine Designation

This training material describes the N55B30M0 in detail.

In the technical documentation, the engine designation is used for unique identification of the engine. In the technical documentation you will also find the abbreviated engine designation, i.e. N55, that only indicates the engine type.

Item	Meaning	Index / explanation
1	Engine developer	M, N = BMW Group P = BMW Motorsport S = BMW M mbH W = Non-BMW engines
2	Engine type	1 = R4 (e.g. N12) 4 = R4 (e.g. N43) 5 = R6 (e.g. N55) 6 = V8 (e.g. N63) 7 = V12 (e.g. N73) 8 = V10 (e.g. S85)
3	Change to the basic engine concept	0 = basic engine 1 – 9 = changes, e.g. combustion process
4	Working method or fuel type and possibly installation position	B = Gasoline, longitudinal installation D = Diesel, longitudinal installation H = Hydrogen
5	Displacement in liters	1 = 1 liter (whole number of liters)
6	Displacement in 1/10 liter	8 = 0.8 liter (tenth of liter)
7	Performance class	K = Smallest U = Lower M = Middle O = Upper (standard) T = Top S = Super
8	Revision relevant to approval	0 = New development 1 – 9 = Revision

## Breakdown of N55 Engine Designation

Index	Explanation
N	BMW Group Development
5	Straight 6 engine
5	Engine with direct injection, VALVETRONIC and exhaust turbocharger
B	Gasoline engine, longitudinal
30	3.0-liter capacity
M	Medium performance class
0	New development

## Engine Identification

The engines are marked on the crankcase with an engine identification code for unique identification. This engine identifier is also required for approval by the authorities. The N55 engine further develops this identification system and the code has been reduced from previously eight to seven characters. The engine serial number can be found under the engine identifier on the engine. Together with the engine identifier, this consecutive number enables unique identification of each individual engine.

Item	Meaning	Index / explanation
1	Engine developer	M, N = BMW Group P = BMW Motorsport S = BMW M GmbH W = Non-BMW engines
2	Engine type	1 = R4 (e.g. N12) 4 = R4 (e.g. N43) 5 = R6 (e.g. N55) 6 = V8 (e.g. N63) 7 = V12 (e.g. N73) 8 = V10 (e.g. S85)
3	Change to the basic engine concept	0 = basic engine 1 – 9 = changes, e.g. combustion process
4	Working method or fuel type and possibly installation position	B = Gasoline, longitudinal installation D = diesel, longitudinal installation H = hydrogen
5	Displacement in liters	1 = 1 liter (whole number of liters)
6	Displacement in 1/10 liter	8 = 0.8 liter (tenth of liter)
7	Type test concerns (changes that require a new type test)	A = Standard B – Z = Depending on requirement, e.g. RON 87

**N55 engine, engine identification and engine serial number**



Index	Explanation
08027053	Individual consecutive engine serial number
N	Engine developer, BMW Group
5	Engine type, straight 6
5	Change to basic engine concept, turbocharging, VALVETRONIC, direct fuel injection
B	Operating principle or fuel supply and installation position, petrol engine longitudinal
30	Displacement in 1/10 liter, 3 liter
A	Type approval requirements, standard



# Engine Mechanical

## Engine Housing

The engine housing consists of the engine block (crankcase and bedplate), cylinder head, cylinder head cover, oil pan and gaskets.

## Engine Block

The engine block is made from an aluminum die-casting and consists of the crankcase with bedplate.

## Crankcase and Bedplate

The crankcase features cast iron cylinder liners (2). A new feature is that the webs between two cylinders on the deck of the block now have a grooved cooling passage (3). Coolant can flow along these grooves from one side of the crankcase to the other, thus enhancing cooling of this area.

Five oil return ducts on the exhaust side (4) now permit oil to return from the cylinder head into the oil pan. These oil return channels extend into the bedplate up to below the oil deflector. They help reduce churning losses as the returning engine oil can no longer reach the crankshaft even at high transverse acceleration.

Five oil return channels on the intake side (5) also ensure that the blow-by gasses can flow unobstructed from the crankshaft area into the cylinder head and to the crankcase breather in the cylinder head cover.

The cooling duct (1) in the engine block is split and coolant flows directly through it.

**N55, crankcase with web cooling**

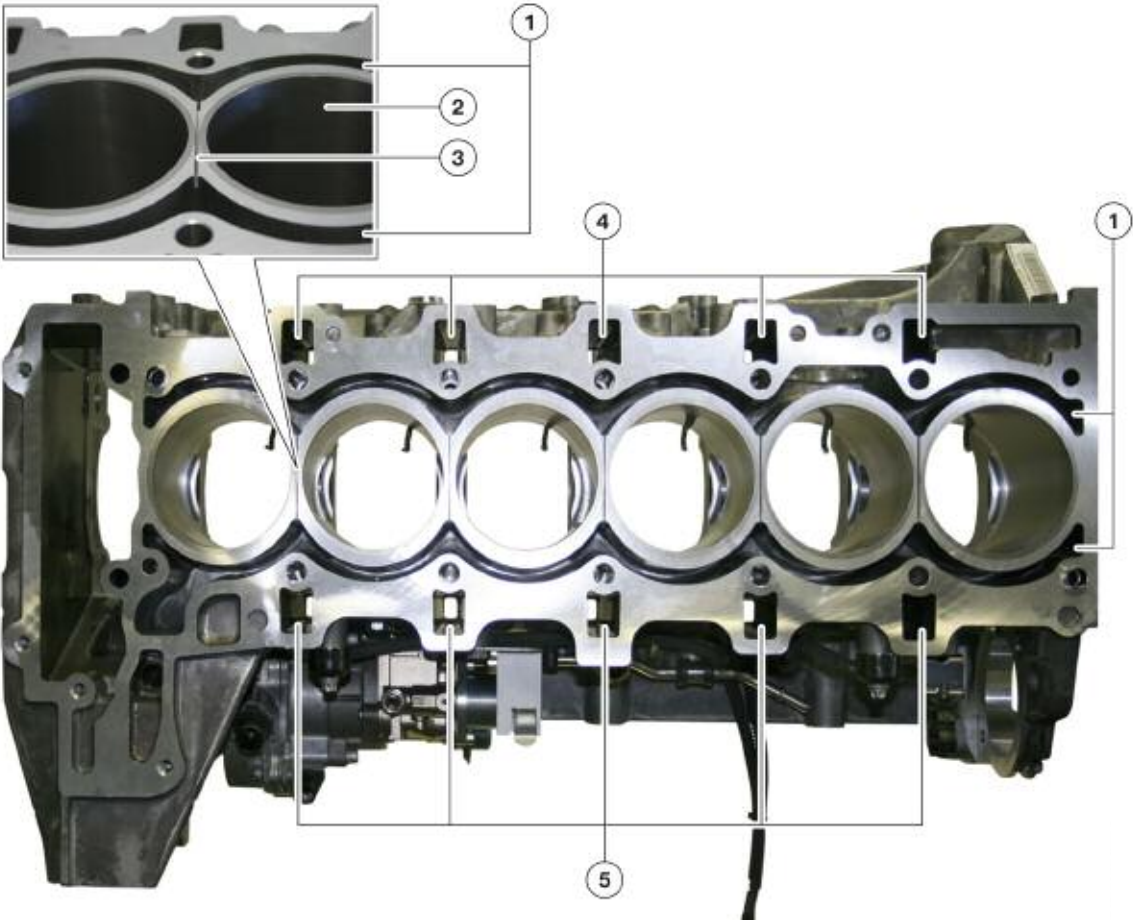

Index	Explanation
1	Cooling duct
2	Cylinder liner
3	Grooved cooling passage
4	Oil return ducts, exhaust side
5	Oil return ducts, intake side

---

The crankcase has large longitudinal ventilation holes bored between the lower chambers of the cylinders. The longitudinal ventilation holes improve the pressure equalization, between the oscillating air columns that are created in the crankcase, by the up and down movement of the pistons.

This enhances power by relieving the unwanted pressure that acts against the downward movement of the pistons. It also enhances crankcase ventilation and adds to oil service life by promoting the movement of blow-by gasses within the engine.

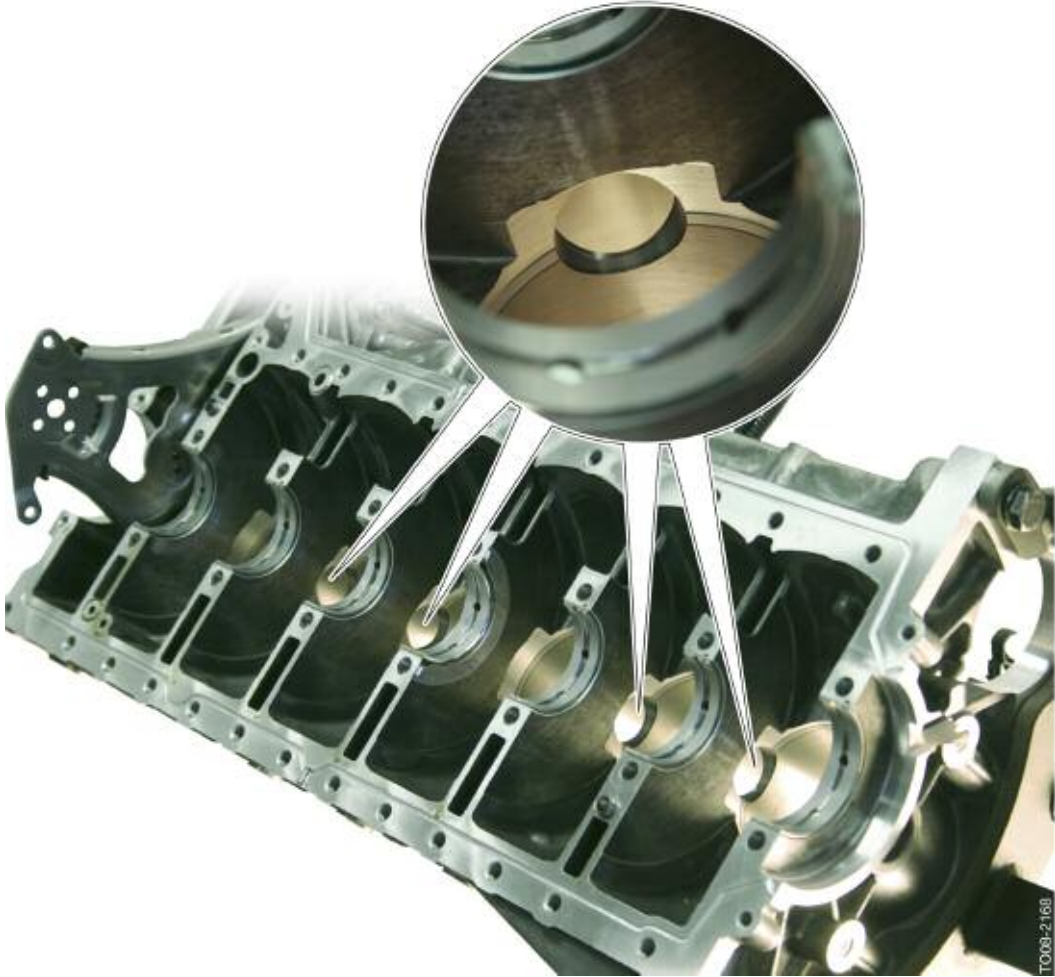

**N55, ventilation holes in crankcase**

## Crankshaft

The crankshaft of the N55 is of lightweight design, at 20.3 kg it's approximately 3 kg lighter than the crankshaft in the N54 engine.

The crankshaft is made from cast iron (GGG70). The counterweights are arranged asymmetrically. There is no incremental wheel installed on the crankshaft. The timing chains are mounted by means of an M18 central bolt.

### N55 Crankshaft

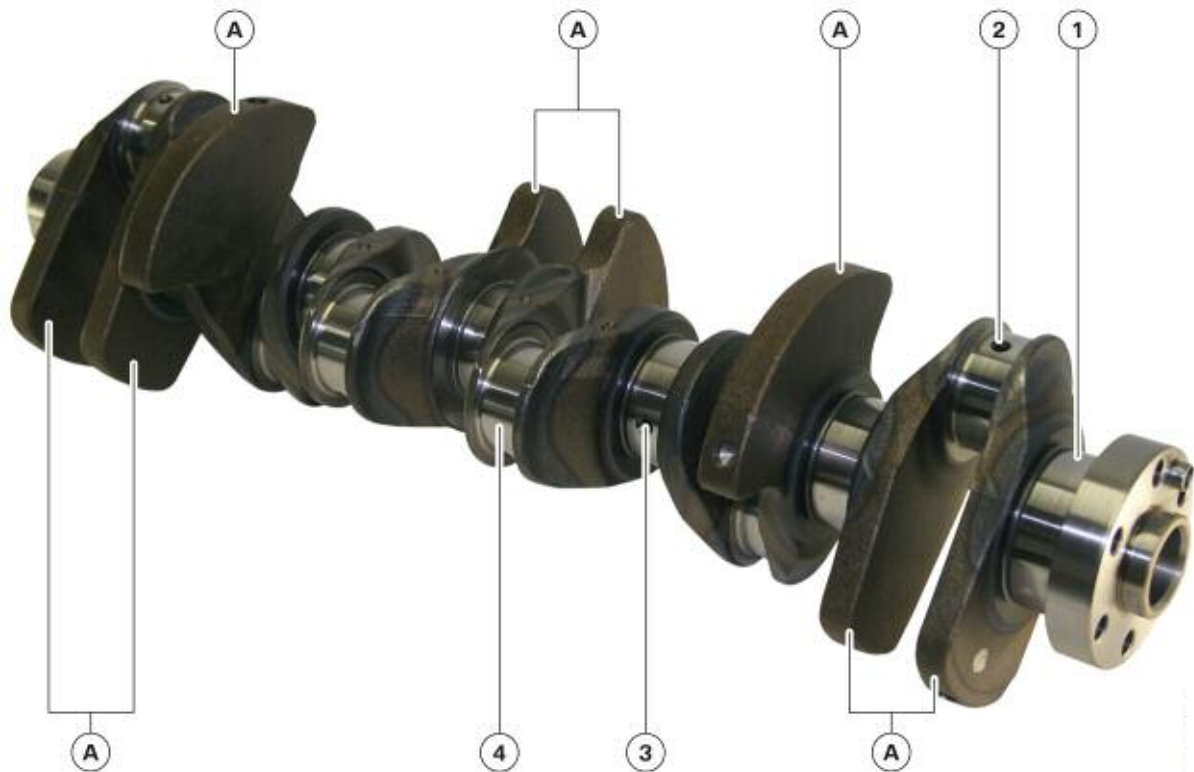

Index	Explanation
A	Counterweights
1	Main bearing journal 7
2	Oil hole from big-end bearing to main bearing
3	Oil hole from main bearing to big-end bearing
4	Big-end bearing journal, cylinder 4

### Crankshaft Main Bearings

As on the N54 engine, the main bearings on the crankshaft are designed as two component bearings free of lead. The thrust bearing is mounted at the fourth bearing position.

## Pistons and Rings

A full slipper skirt type piston with a diameter of 82.5 mm is used. The first piston ring is a plain rectangular compression ring with a chrome-ceramic coating on the contact surface. The second piston ring is a tapered faced Napier type ring. The oil scrape ring is designed as a steel band ring with spring that is also known as VF system.

### N55 piston with piston rings



Index	Explanation
1	Plain rectangular compression ring
2	Tapered faced Napier ring
3	VF system ring
4	Steel inlay for first piston ring
5	Groove for first piston ring
6	Groove for second piston ring
7	Groove for oil scraper ring
8	Hole for lubricating oil drain
9	Graphite coating

## Connecting Rod and Bearings

The size of the connecting rod of the N55 engine is 144.35 mm. A new feature is the specially formed hole in the small end of the connecting rod. This formed hole is machined wider on the lower edges of the wrist pin bushing/bore. This design evenly distributes the force acting on the wrist pin over the entire surface of the rod bushing and reduces the load at the edges, as the piston is forced downward on the power stroke.

### N55, small end of the connecting rod

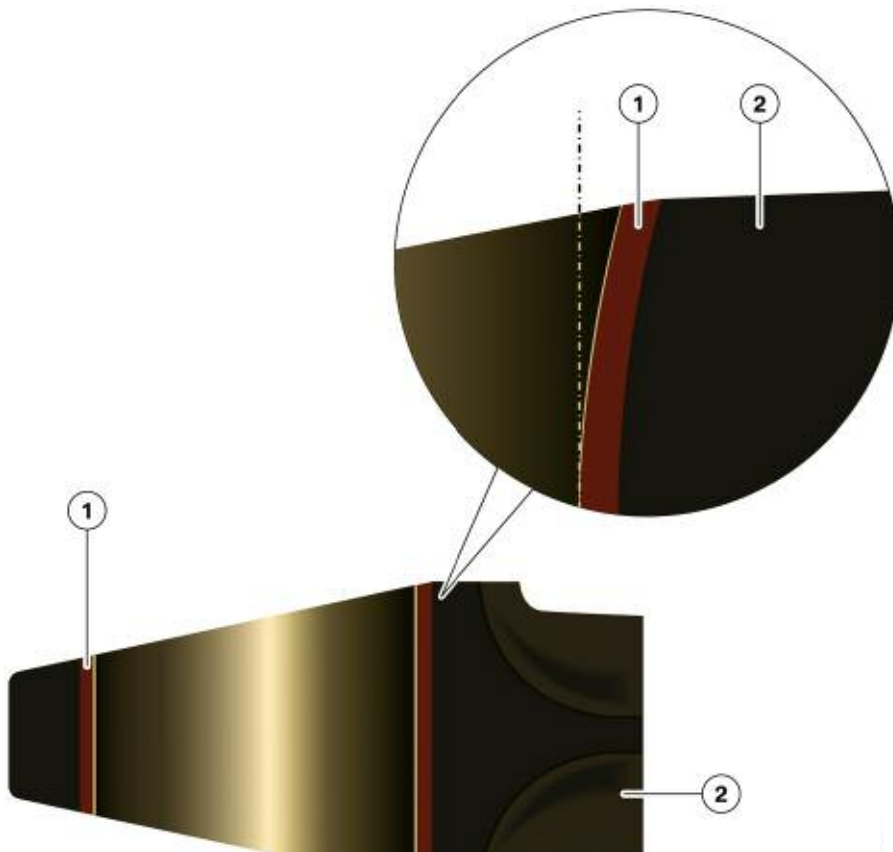

Index	Explanation
1	Bushing
2	Connecting rod

---

NOTES

PAGE

The following graphic shows the surface load on a standard connecting rod without the formed hole. Due to combustion pressure, the force exerted by the piston via the wrist pin is mainly transmitted to the edges of the rod bushing.

**N54, connecting rod small end without formed hole**

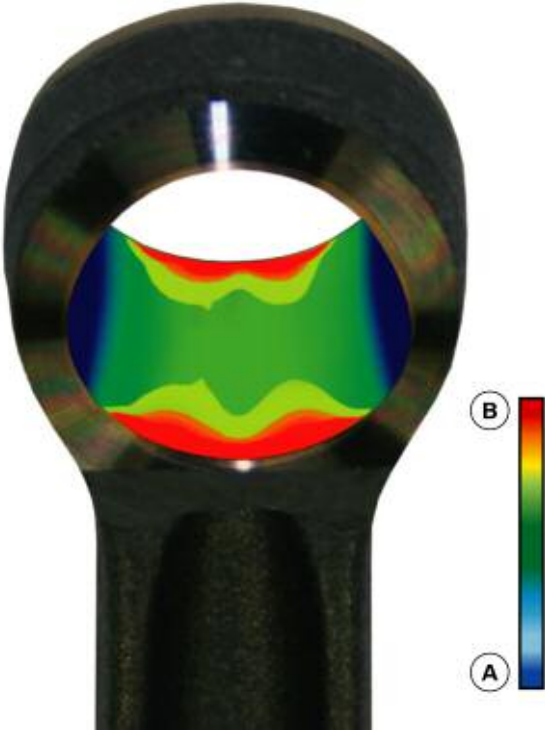

Index	Explanation
A	Low surface load
B	High surface load



The graphic below illustrates the small end of the connecting rod with a formed hole. The force is more evenly distributed over a larger area and the load on the edges of the rod bushing is reduced considerably.

**N55, connecting rod small with formed hole**

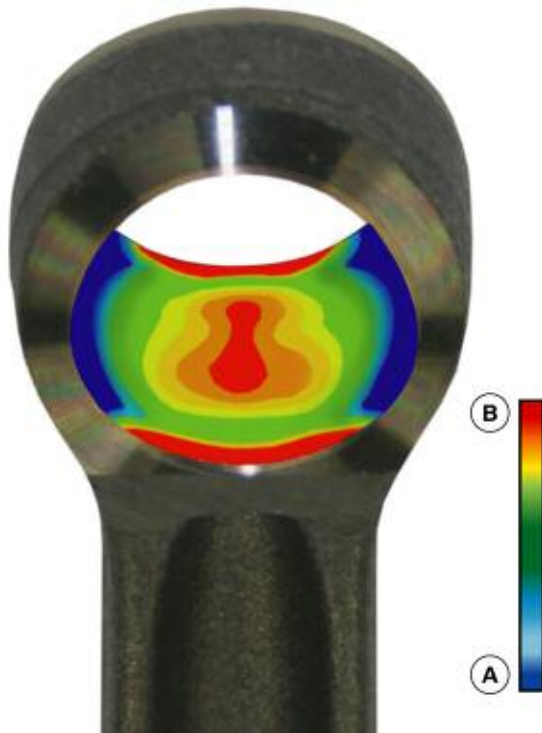

Index	Explanation
A	Low surface load
B	High surface load

Lead-free bearing shells are used on the large connecting rod end. The material G-488 is used on the connecting rod side and the material G-444 on the bearing cap side.

The size M9 x 47 connecting rod bolts are the same on the N55 and N54 connecting rod.

## Oil Pan

The oil pan is made from an aluminum casting. The oil deflector and the intake pipe to the oil pump are designed as one component. To facilitate attachment to the bedplate, the oil return ducts are designed so that they extend over the oil deflector. Consequently, the oil return ducts end in the oil sump.

Ducts are provided for the oil supply to the vacuum pump as it is now lubricated by filtered oil and not by unfiltered oil as on the N54 engine.

### N55, bedplate with oil pump and oil deflector

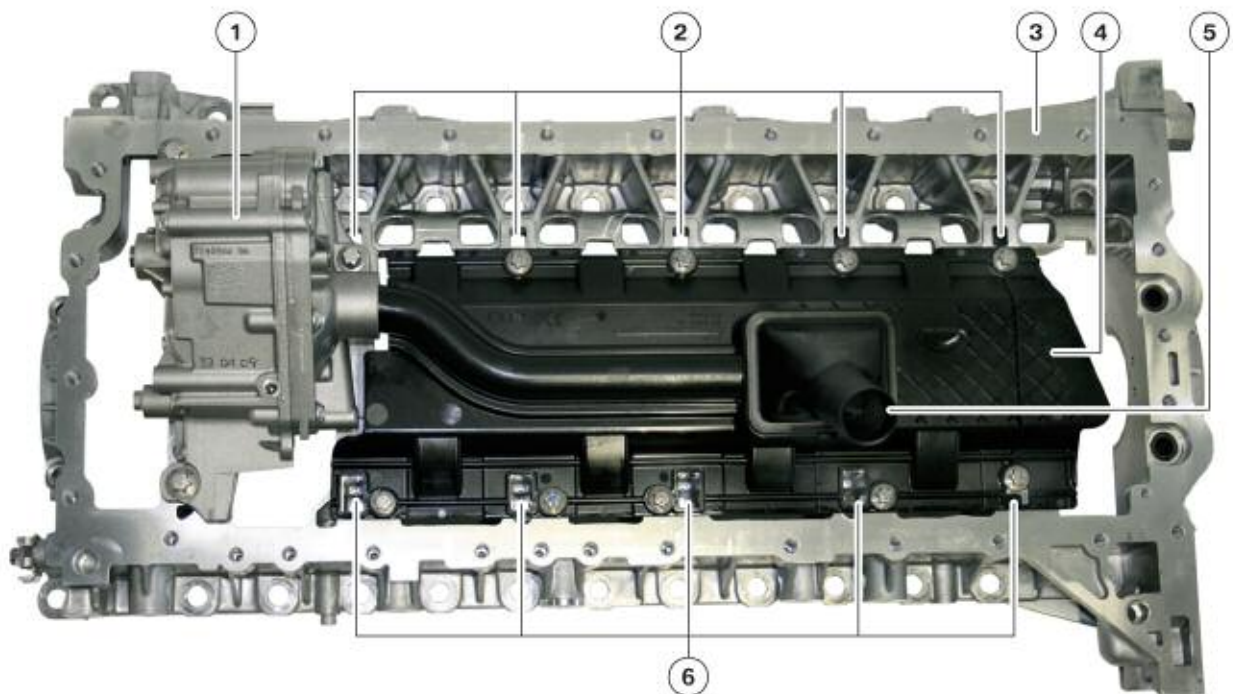

Index	Explanation
1	Oil pump
2	Oil return ducts, intake side
3	Bedplate
4	Oil deflector
5	Intake manifold with oil screen filter
6	Oil return ducts, exhaust side

## Electronic Volume-controlled Oil Pump

A modified version of the volume control oil pump of the N54 engine is used. For the first time a Duroplast reciprocating slide valve is installed. The volumetric flow control system operating principle of the oil pump is described in the E71 X6 training material under the "N63 Engine" available on TIS and ICP.

This type of pump delivers only as much oil as is necessary under the respective engine operating conditions. No surplus quantities of oil are delivered in low-load operating ranges. This operating mode reduces the pump work and therefore the fuel consumption of the engine while also slowing down the oil aging process. The pump is designed as a slide valve-type vane pump. In delivery mode, the pump shaft is positioned off-center in the housing and the vanes are displaced radially during rotation. As a result, the vanes form chambers of differing volume. The oil is drawn in as the volume increases and expelled into the oil galleries as the volume decreases.

The oil pressure in the system (downstream of the oil filter) acts on the slide against the force of a compression springs in the control oil chamber. The slide element rotates about a pivot axis.

### N55, oil pump

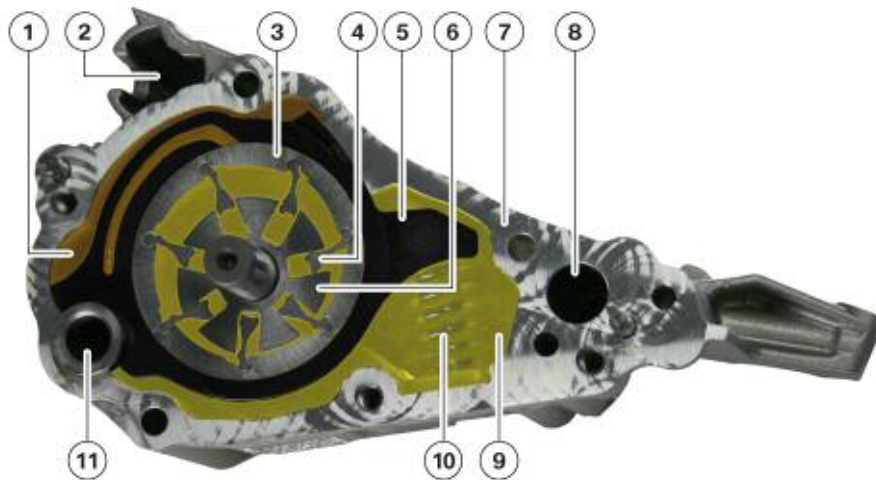

Index	Explanation	Index	Explanation
1	Control oil chamber	7	Housing
2	Pressure limiting valve	8	Hole for pressure control valve
3	Rotor	9	Damping oil chamber
4	Vane	10	Compression spring (2x)
5	Duroplast slide valve	11	Pivot axis of rotation
6	Inner rotor		

## Oil Pump and Pressure Control

The oil pump has been redesigned with regard to the functionality and durability of the Duroplast reciprocating slide valve. The oil pump used in the N55 engine is a further development of the shuttle slide valve volume control oil pump. The activation of the oil pump is adapted by the engine management and controlled through an oil pressure control valve.

The delivered oil volume is controlled by means of the oil pressure, based on specific requirements. The modifications, compared to previous pumps, are primarily in the pump activation system. The oil pressure no longer acts directly on the control piston but rather directly on the slide valve. The engine management activates the electrohydraulic pressure control valve, which affects the oil pressure at the slide valve control mechanism within the oil pump, altering the pump output. This has the advantage of avoiding power losses by running the oil pump only when needed.

The electrohydraulic pressure control valve controls the pump output and is bolted to the front of the engine block. It is operated based on a characteristic map within the DME (ECM) which in turn is based on feedback from the oil pressure sensor. The N55 uses a special oil pressure sensor for this purpose which functions in the similar way as the HPI fuel pressure sensor.

### Characteristic map-controlled oil pressure

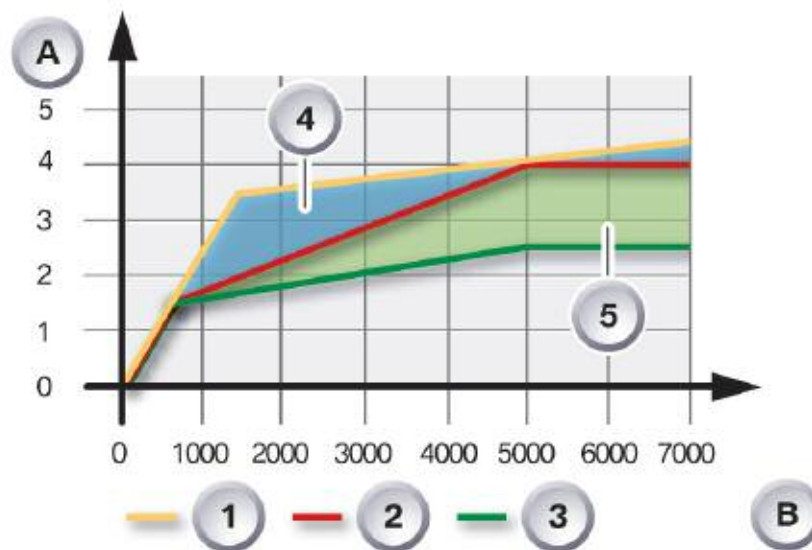

Index	Explanation	Index	Explanation
A	Oil pressure (bar)	3	Characteristic map-controlled oil pressure, no load
B	Engine speed (rpm)	4	Saving potential, full load
1	Oil pressure control, hydraulic/ mechanical	5	Saving potential, no load
2	Characteristic map-controlled oil pressure, full load		



**N55, oil pump and pressure control valve**

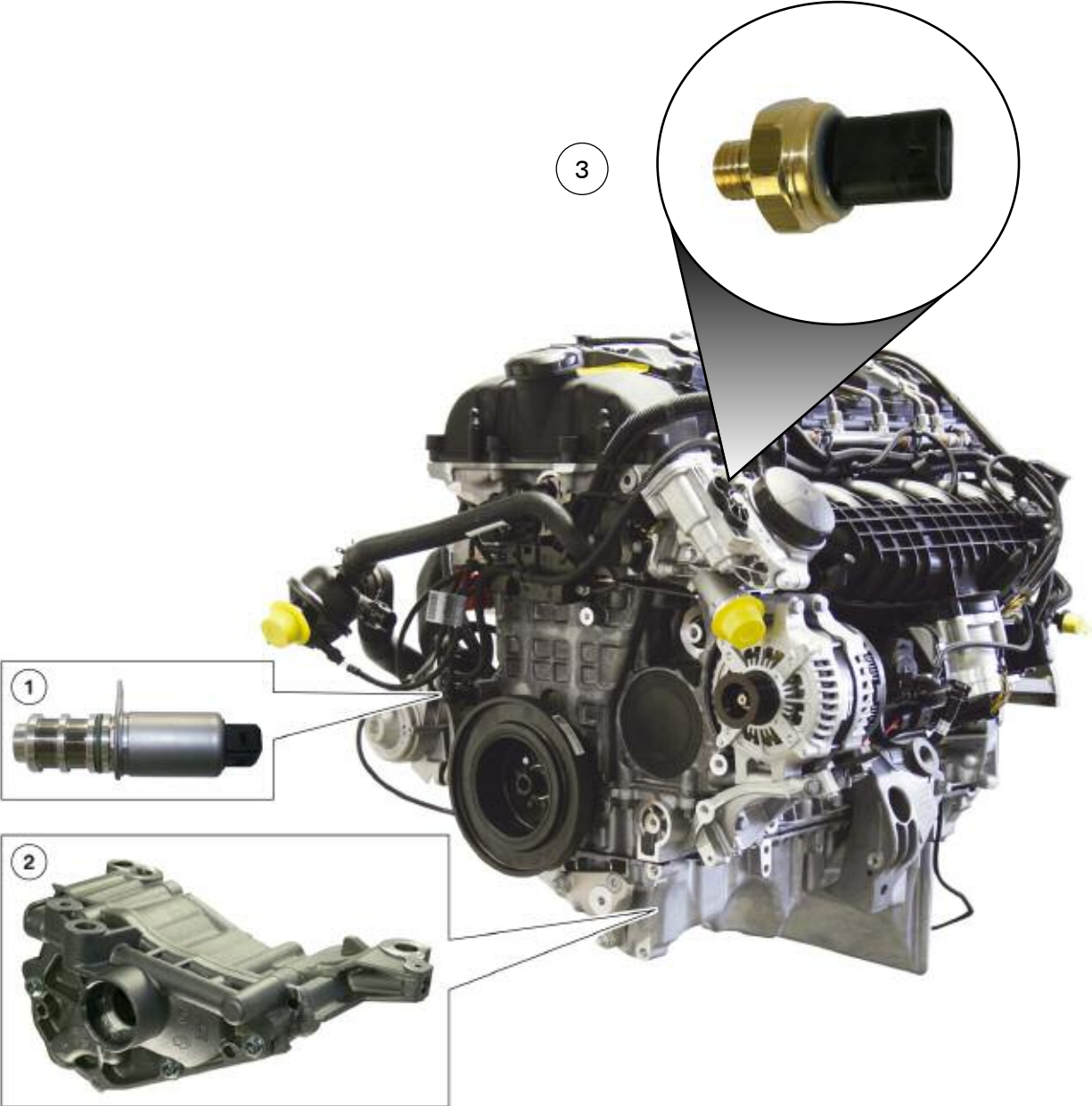

Index	Explanation
1	Oil pressure control valve
2	Oil pump
3	Oil pressure sensor

---

NOTES

PAGE

## Oil Supply

The following graphics show an overview of the oil circuit of the N55. Compared to the N54 engine, there are considerably fewer oil ducts in the cylinder head. This is mainly due to the use of the new VANOS solenoid valves.

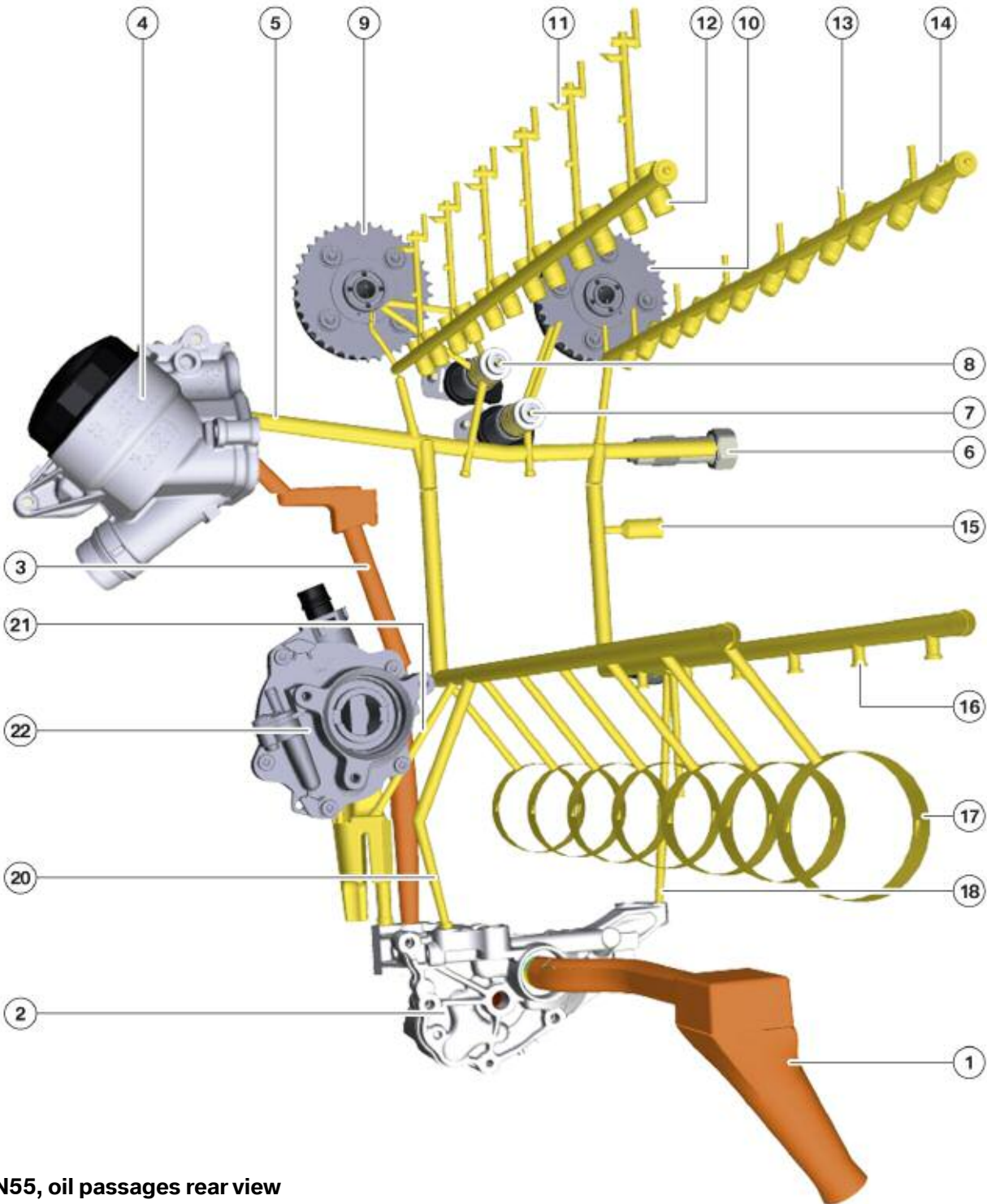

**N55, oil passages rear view**



<b>Index</b>	<b>Explanation</b>
1	Intake pipe
2	Oil pump
3	Unfiltered oil duct
4	Oil filter
5	Main oil duct (filtered oil duct)
6	Chain tensioner
7	VANOS solenoid valve, exhaust side
8	VANOS solenoid valve, intake side
9	VANOS adjustment unit, intake side
10	VANOS adjustment unit, exhaust side
11	Oil duct for intake camshaft and eccentric shaft lubrication
12	Hydraulic valve lash adjustment
13	Oil duct for exhaust camshaft lubrication
14	Hydraulic valve lash adjustment
15	Connection to exhaust turbocharger lubrication
16	Connection for oil spray nozzles
17	Crankshaft bearing
18	Oil duct for oil pressure control
20	Oil duct for oil pressure control
21	Oil duct for vacuum pump lubrication
22	Vacuum pump

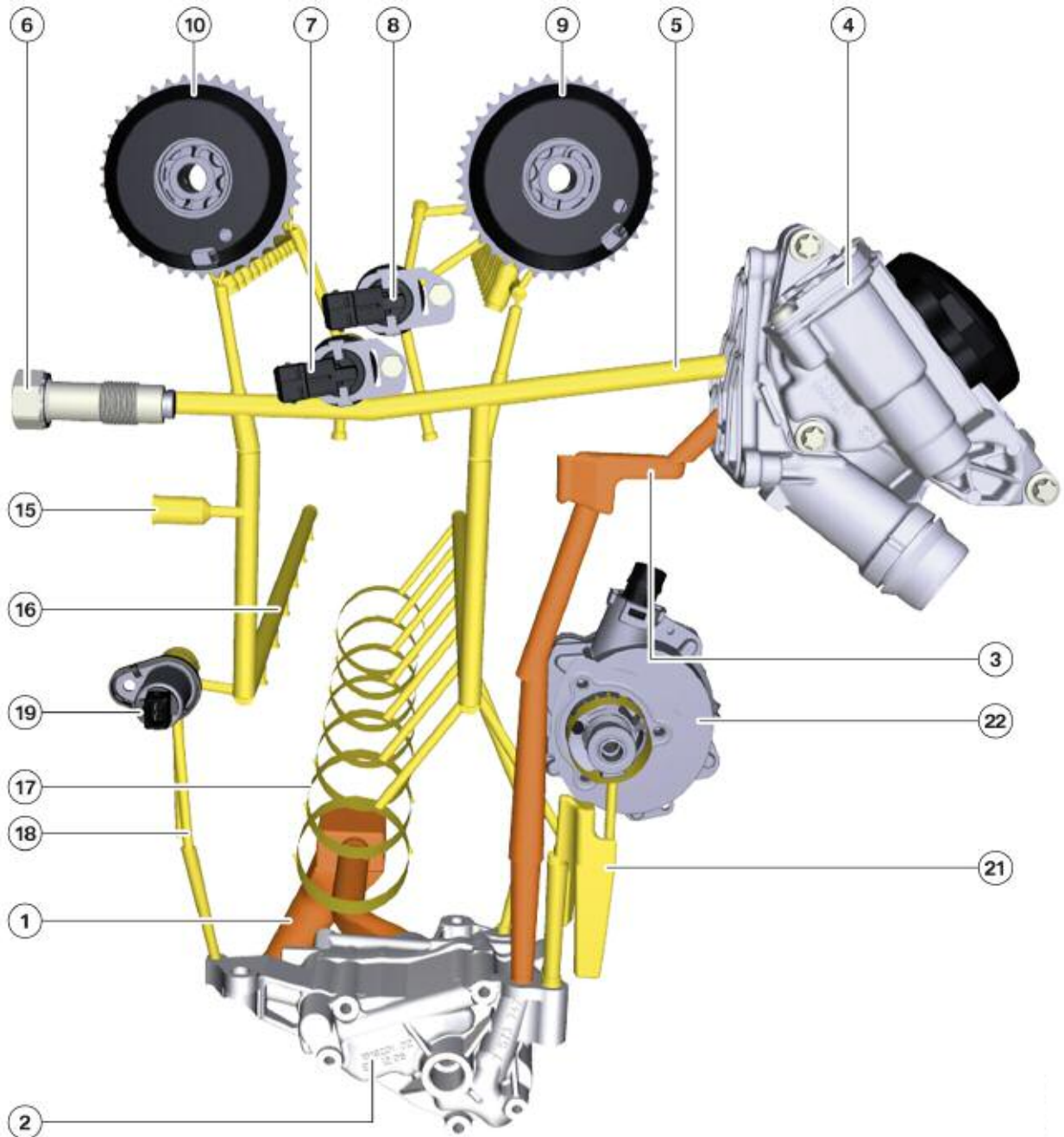

**N55, oil passages front view**

Index	Explanation
1	Intake pipe
2	Oil pump
3	Unfiltered oil duct
4	Oil filter
5	Main oil duct (filtered oil duct)
6	Chain tensioner
7	VANOS solenoid valve, exhaust side
8	VANOS solenoid valve, intake side
9	VANOS adjustment unit, intake side
10	VANOS adjustment unit, exhaust side
15	Connection to exhaust turbocharger lubrication
16	Connection for oil spray nozzles
17	Crankshaft bearing
18	Oil duct for oil pressure control
19	Oil pressure control valve
21	Oil duct for vacuum pump lubrication
22	Vacuum pump

### Oil Filtration and Oil Cooling

The oil filter housing is made from Duroplast. Based on the application, two types of engine oil coolers may be used. Depending on the oil temperature, a thermostat on the oil filter housing controls the oil flow through the oil cooler.

## Oil Spray Nozzles

The N55 engine is equipped with oil spray nozzles for the purpose of cooling the piston crown. A special tool is required for positioning the oil spray nozzles.

## Oil Pressure

Since the N55 engine has an oil pump with electronic volumetric flow control, it is necessary to measure the oil pressure precisely. For this reason, a new oil pressure sensor is installed.

Advantages of the new pressure sensor:

- It now measures absolute pressure (previous measured relative pressure).
- It is characteristic map control in all speed ranges.

## Oil Level

The oil quality sensor is used for measuring the oil level as on previous BMW engines.

## Oil Return

The following graphics show the integrated oil deflector. It combines the following components:

- Oil deflector (4)
- Intake snorkel (5)

The oil sump (1) and crankshaft are separated by the integrated oil deflector. Oil scraper edges are installed on the bedplate to direct the spray oil from the crankshaft.

Depending on the model, the oil pan can be adapted to different installation configurations by simply changing the intake snorkel. The oil, flowing back from the cylinder head (2, 6) is directed under the oil deflector. In this way, even under high transverse acceleration conditions, no returning oil can reach the crankshaft and cause churning losses .

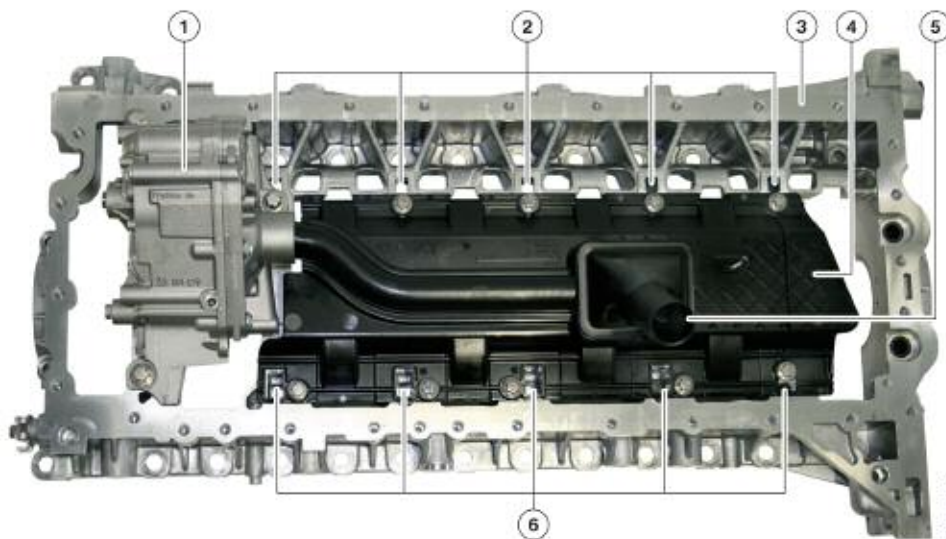

---

## Cylinder Head

Direct fuel injection, turbocharging and VALVETRONIC systems are combined for the first time on a BMW 6-cylinder engine. The cylinder head of the N55 engine is a new development. It features a very compact design and is equipped with third generation VALVETRONIC.

The combination is referred to as Turbo-VALVETRONIC-Direct-Injection (TVDI).

This system reduces CO<sub>2</sub> emission and fuel consumption by 3 - 6%.

There are now no connections for the VANOS non-return valves as they have been integrated in the solenoid valves. The cylinder head also features cooling passages near the fuel injectors; providing indirect cooling.

### N55, cylinder head



## Cylinder Head Cover

The cylinder head cover is a new development. The accumulator for the vacuum system is built into the cylinder head cover.

All components for crankcase ventilation and the blow-by channels are also integrated into the cylinder head cover. The non-return valves ensure that the blow-by gasses are reliably added to the intake air in both engine modes (NA and Boost)

The N55 engine is equipped with a vacuum-controlled crankcase ventilation system; therefore, a regulated negative pressure of approximately 38 mbar is maintained.

### N55, cylinder head cover with crankcase ventilation



Index	Explanation
1	Connection, blow-by gas to clean air pipe
2	Connection, vacuum line to vacuum pump
3	Reserve, vacuum connection
4	Vacuum connection to electropneumatic pressure converter EPDW for wastegate valve
5	Duct for blow-by gas feed into intake system with integrated non-return valve
6	Blow-by gas duct with settling chamber, impact plate, pressure control valve and non-return valves
7	Pressure regulating valve

---

## **Crankcase Ventilation**

The blow-by gasses flow into the settling chamber of the cylinder head cover through an opening located in the rear of the cover. Here, the blow-by gasses are directed through holes on to an impact plate, against which the oil impacts at high speed, and drains off. The blow-by gasses, cleaned of oil, flow via the pressure control valve (depending on the operating mode) through the non-return valves into the inlet pipe upstream of the turbocharger, or via passages in the cylinder head ahead of the intake valves. The separated oil is drained via a return flow duct into the oil pan.

### **Naturally Aspirated Mode**

The standard function can only be used as long as a vacuum prevails in the intake air manifold, i.e. in naturally-aspirated engine mode.

With the engine operating in naturally-aspirated mode, the vacuum in the intake air manifold opens the non-return valve (15) in the blow-by duct within the cylinder head cover. This draws off blow-by gasses via the pressure control valve. At the same time, the vacuum also closes the second non-return valve (12) in the duct to the charge air intake pipe.

The blow-by gasses flow via a distribution rail integrated in the cylinder head cover, through the intake passages (16) in the cylinder head, which lead directly into the intake ports, ahead of the valves.

**N55, crankcase ventilation, naturally-aspirated mode**

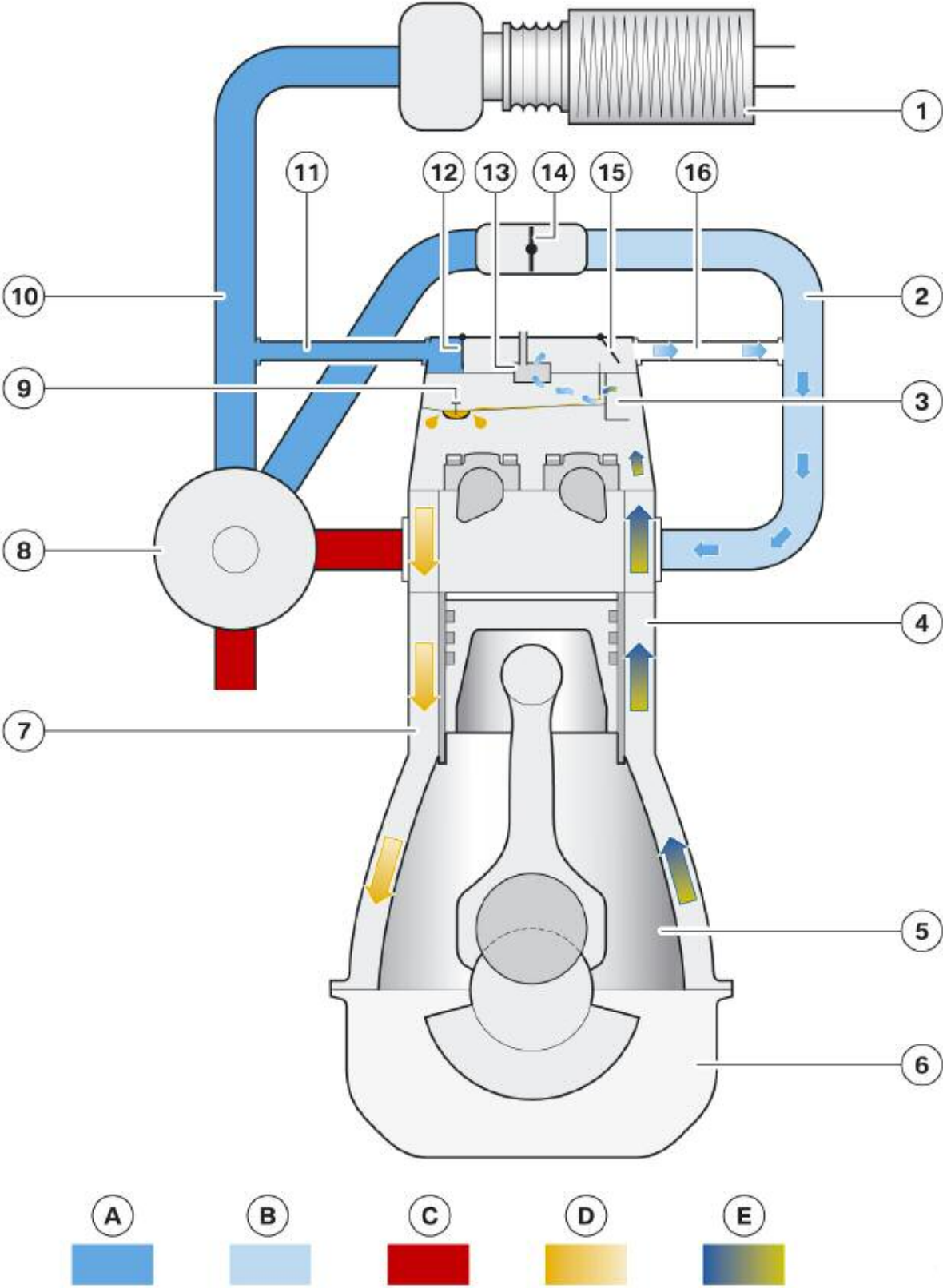



Index	Explanation
A	Ambient pressure
B	Vacuum
C	Exhaust gas
D	Oil
E	Blow-by gas
1	Air cleaner
2	Intake manifold
3	Impact plates
4	Oil return channel
5	Crankcase
6	Oil sump
7	Oil return channel
8	Exhaust turbocharger
9	Oil drain valve
10	Charge air intake line
11	Hose to charge air intake line
12	Non-return valve
13	Pressure regulating valve
14	Throttle valve
15	Non-return valve
16	Passages in cylinder head and cylinder head cover

### Boost Mode

As the pressure in the intake air manifold increases in boost mode, blow-by gasses can no longer be introduced via the passages in the cylinder head, otherwise, the boost pressure could enter the crankcase. A non-return valve (15) in the blow-by channel within the cylinder head cover closes the connection (16) to the intake air manifold. This protects the crankcase from excess pressure.

The increased demand for fresh air creates a vacuum in the clean air pipe between the turbocharger and intake silencer. This vacuum is sufficient to open the non-return valve (12) and draw the blow-by gasses via the pressure control valve.

**N55, crankcase ventilation, turbocharged (boost) mode**

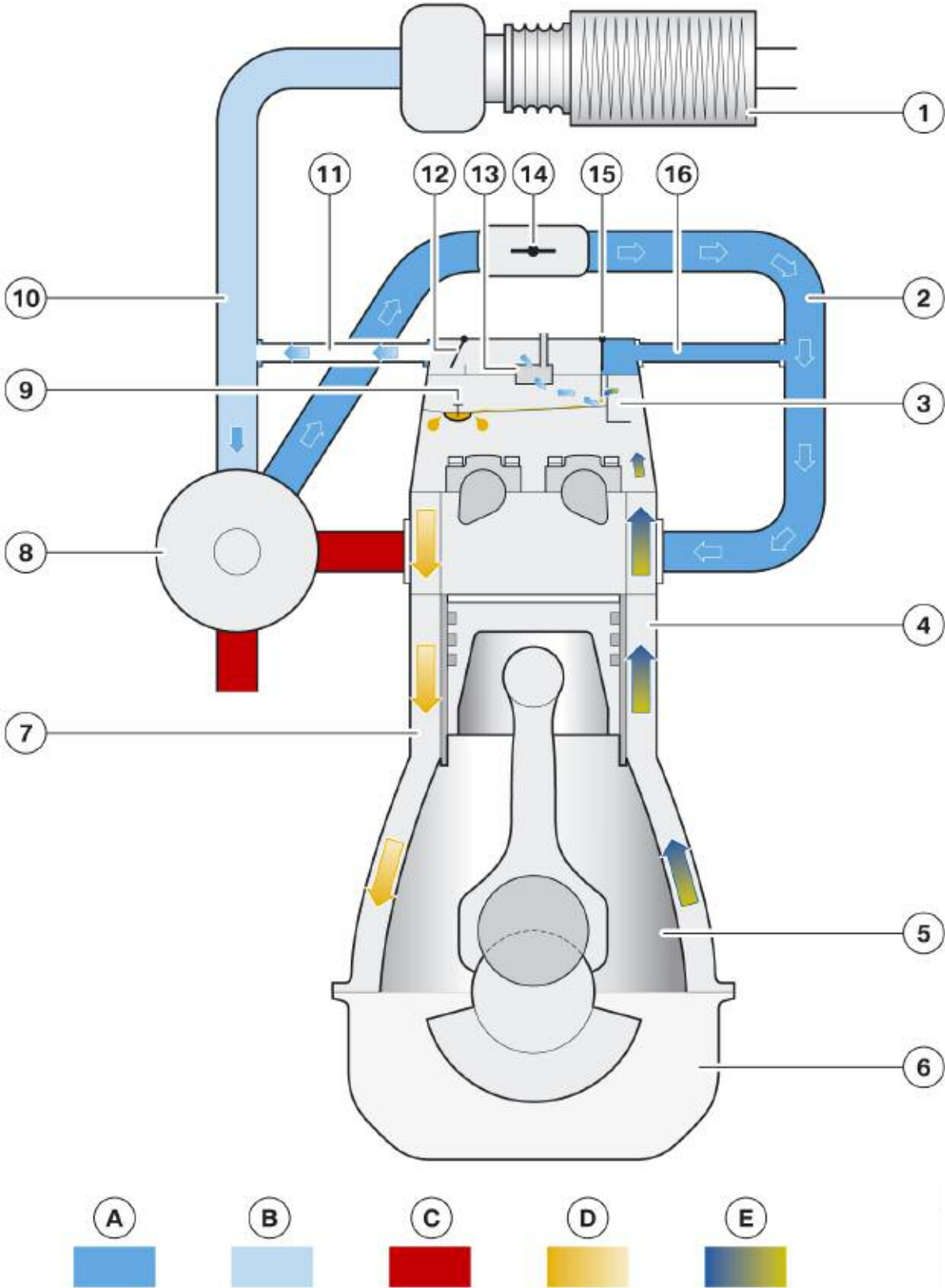

Index	Explanation
A	Excess pressure
B	Vacuum
C	Exhaust gas
D	Oil
E	Blow-by gas
1	Air cleaner
2	Intake manifold
3	Impact plates
4	Oil return channel
5	Crankcase
6	Oil sump
7	Oil return channel
8	Exhaust turbocharger
9	Oil drain valve
10	Charge air intake line
11	Hose to charge air intake line
12	Non-return valve
13	Pressure regulating valve
14	Throttle valve
15	Non-return valve
16	Passages in cylinder head and cylinder head cover



**If a customer complains about high oil consumption and oil is discovered in the turbocharger, it should not be immediately assumed that the turbocharger is defective. If the oil is present in the fresh air pipe (before the turbocharger) then the entire engine should be checked.**

## Valvetrain

The following graphic shows the design of the cylinder head on the N55 engine with VALVETRONIC III and direct fuel injection.

### N55, overview of valvetrain

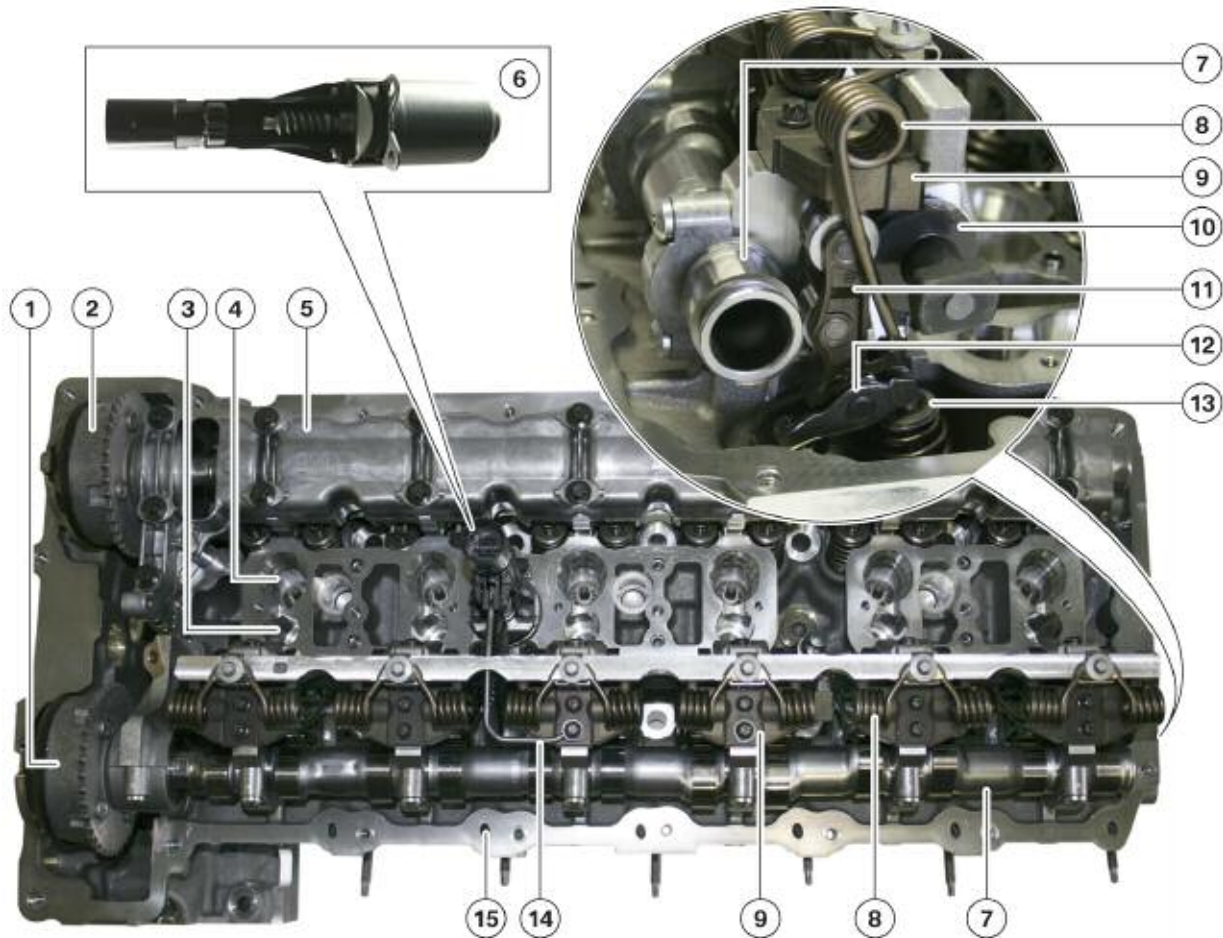

**Notice the hollow, lightweight design of the camshafts (7) and the blow-by passages leading into the intake ports (15).**

Index	Explanation
1	VANOS unit, intake camshaft
2	VANOS unit, exhaust camshaft
3	Injector well
4	Spark plug well
5	Camshaft housing
6	VALVETRONIC servomotor
7	Inlet camshaft
8	Torsion spring
9	Gate
10	Eccentric shaft
11	Intermediate lever
12	Roller lever tappet
13	Valve head
14	Oil spray nozzle
15	Passages for introducing blow-by gas into the intake ports

### Intake and Exhaust Valves

The valve stems have a diameter of 5 mm on the intake valve and 6 mm on the exhaust valve. The larger diameter exhaust valve are hollow and filled with sodium. In addition, the valve seat of the exhaust valves are reinforced.

### Valve Springs

The valve springs are different for the intake side and exhaust side.

# Camshafts

Lightweight camshafts as well as cast camshafts or a mixture of both were installed in N54 engines. Only lightweight construction camshafts are used on the N55 engine. The lightweight camshafts for the N55 are manufactured in an internal high pressure forming process called hydroforming. The exhaust camshaft features bearing races and is encapsulated in a camshaft housing. The camshaft housing reduces oil foaming during operation.

## N55, assembled camshaft



Index	Explanation
1	Shell-shaped cam
2	Corrugated tube

## Valve Timing

### N55 valve timing diagram

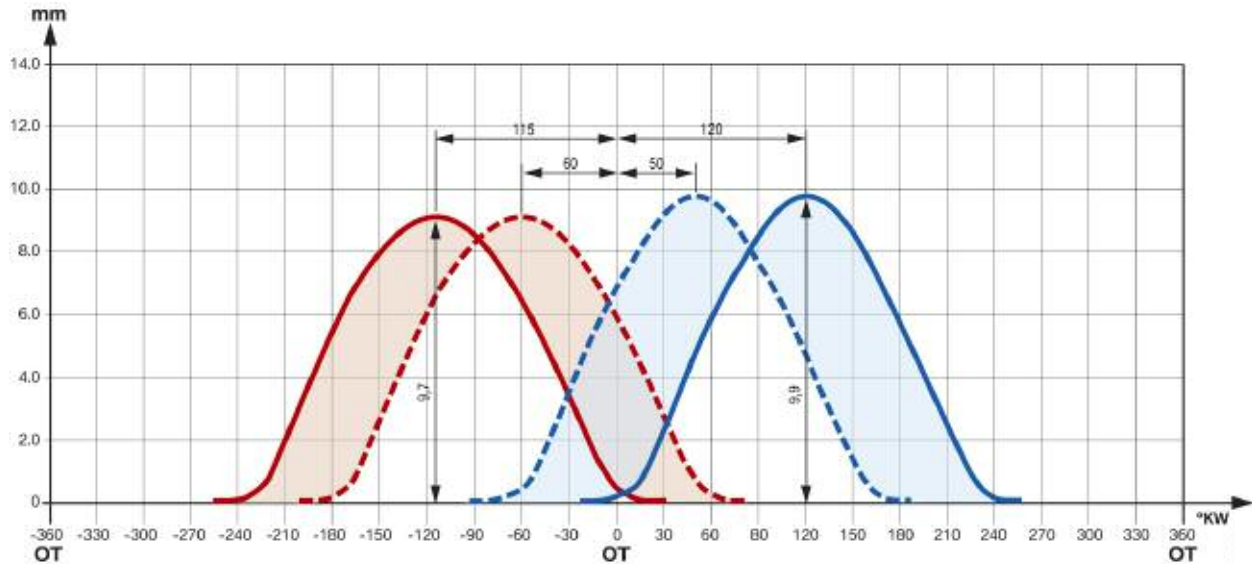

		N54B3000	N55B30M0
Intake valve Ø	[mm]	31.4	32
Exhaust valve Ø	[mm]	28	28
Maximum valve lift, intake valve/exhaust valve	[mm]	9.7/9.7	9.9/9.7
Intake camshaft spread (VANOS adjustment range)	[°crankshaft]	55	70
Exhaust camshaft spread (VANOS adjustment range)	[°crankshaft]	45	55
Intake camshaft opening angle (max.-min. spread)	[°crankshaft]	125 - 70	120 - 50
Exhaust camshaft opening angle (max.-min. spread)	[°crankshaft]	130 - 85	115 - 60
Opening period intake camshaft	[°crankshaft]	245	255
Opening period exhaust camshaft	[°crankshaft]	261	261



**The N55 has a larger intake and exhaust VANOS adjustment range as well as larger intake valve lift, and cam duration than the N54 engine.**

# VANOS System

N54, VANOS with oil supply

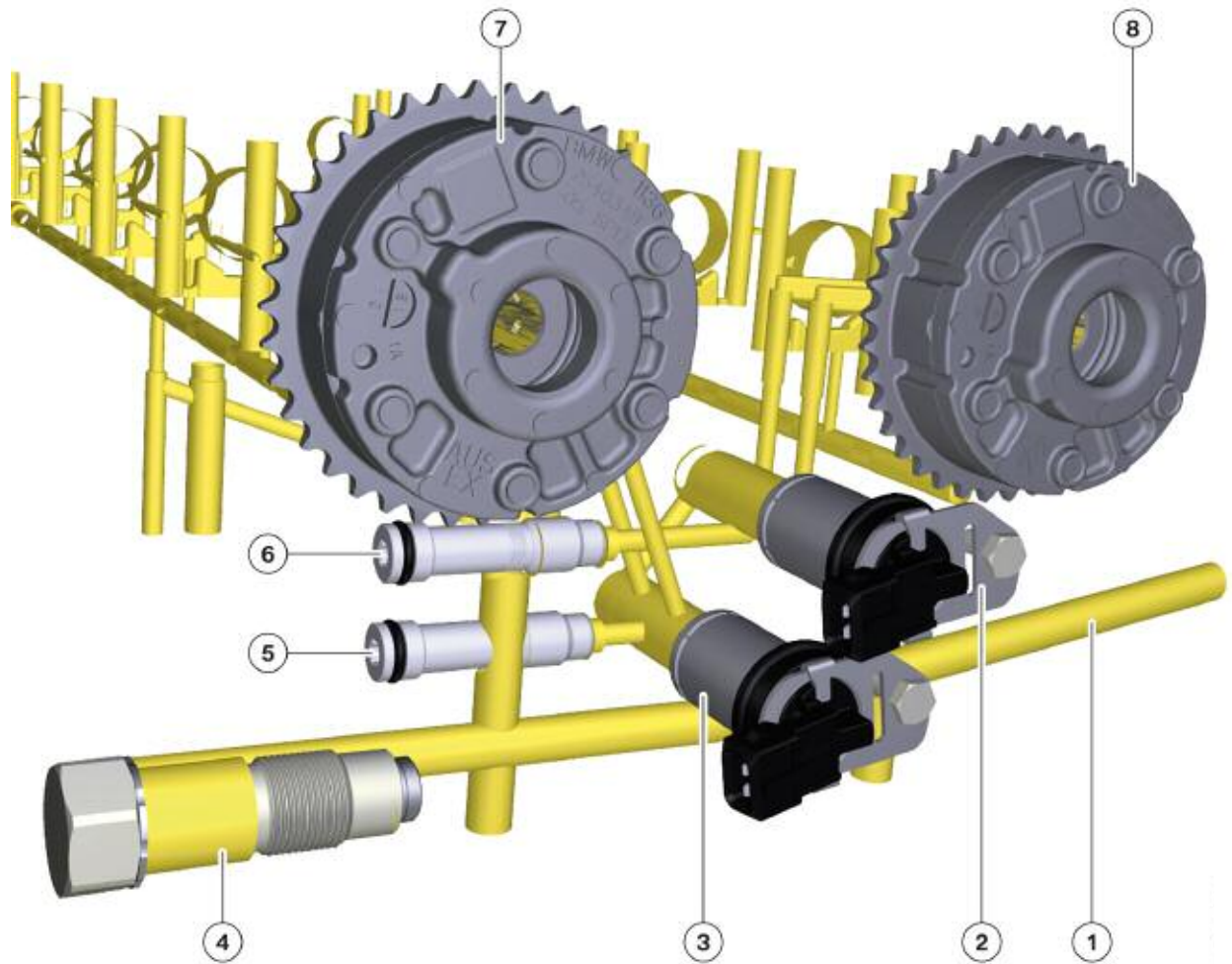

Index	Explanation
1	Main oil duct
2	VANOS solenoid valve, intake side
3	VANOS solenoid valve, exhaust side
4	Chain tensioner
5	Non return valve, exhaust side
6	Non return valve, intake side
7	VANOS adjustment unit, exhaust side
8	VANOS adjustment unit, intake side



## Overview

The VANOS system has been optimized to provide even faster adjustment speeds of the VANOS units. The aluminum VANOS units are much lighter and are also less susceptible to soiling. It can be seen by comparing the N54 VANOS system with the N55 VANOS that fewer oil passages are required and that the non-return valves are no longer on the cylinder head but rather incorporated into the solenoid valves on N55.

### N55, VANOS with oil supply

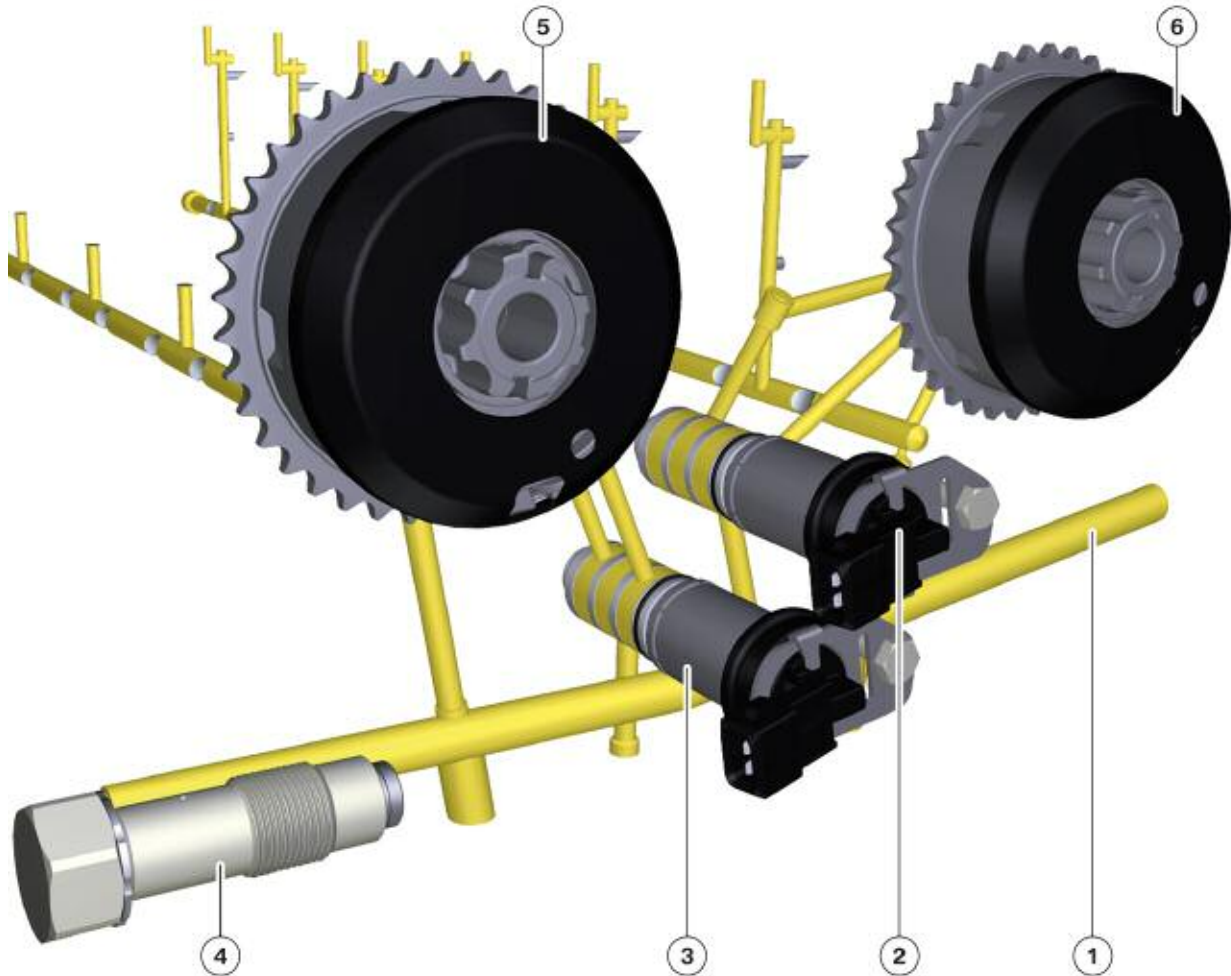

Index	Explanation
1	Main oil duct
2	VANOS solenoid valve, intake side
3	VANOS solenoid valve, exhaust side
4	Chain tensioner
5	VANOS adjustment unit, exhaust side
6	VANOS adjustment unit, intake side

---

### **VANOS Solenoid Valves**

The non-return valve with screen filter used on the N54 engine have now been integrated in the VANOS solenoid valves on the N55 engine. This measure has made it possible to reduce the number of oil ducts in the cylinder head. The screen filters on the VANOS solenoid valve ensure trouble-free operation and reliably prevent the VANOS solenoid valve from sticking due to dirt particles.

### **Cam Sensor Wheels**

The sensor wheels are now “deep-drawn” sheet metal components and no longer made from two parts. This design increases production accuracy while reducing manufacturing costs.

#### **N55, camshaft sensor wheel**



<b>Index</b>	<b>Explanation</b>
A	Rear View
B	Front view

---

## VALVETRONIC III

The main differences between VALVETRONIC III and VALVETRONIC II are in the arrangement of the VALVETRONIC servomotor and the VALVETRONIC sensor. As in VALVETRONIC II, the turbulence level is increased at the end of the compression cycle for the purpose of optimizing the mixture formation with the use of phasing and masking measures. This movement of the cylinder charge improves the combustion during partial load operation and in catalytic converter heating mode. The quench areas also contribute to mixture formation.

### Phasing

Phasing results in a lift difference between both intake valves of up to 1.8 mm in the lower partial load range. Consequently, the flow of fresh air is distributed asymmetrically.

### Masking

Masking refers to the design of the valve seats. This machining ensures that the incoming fresh air is aligned in such a way as to give rise to the required cylinder charge movement. The advantage of this measure is that the combustion retardation is reduced by approximately  $10^\circ$  of crankshaft rotation. The combustion process takes place faster and a larger valve overlap can be achieved, thus considerably reducing NOx emissions.

**N55, Top of the combustion chamber**

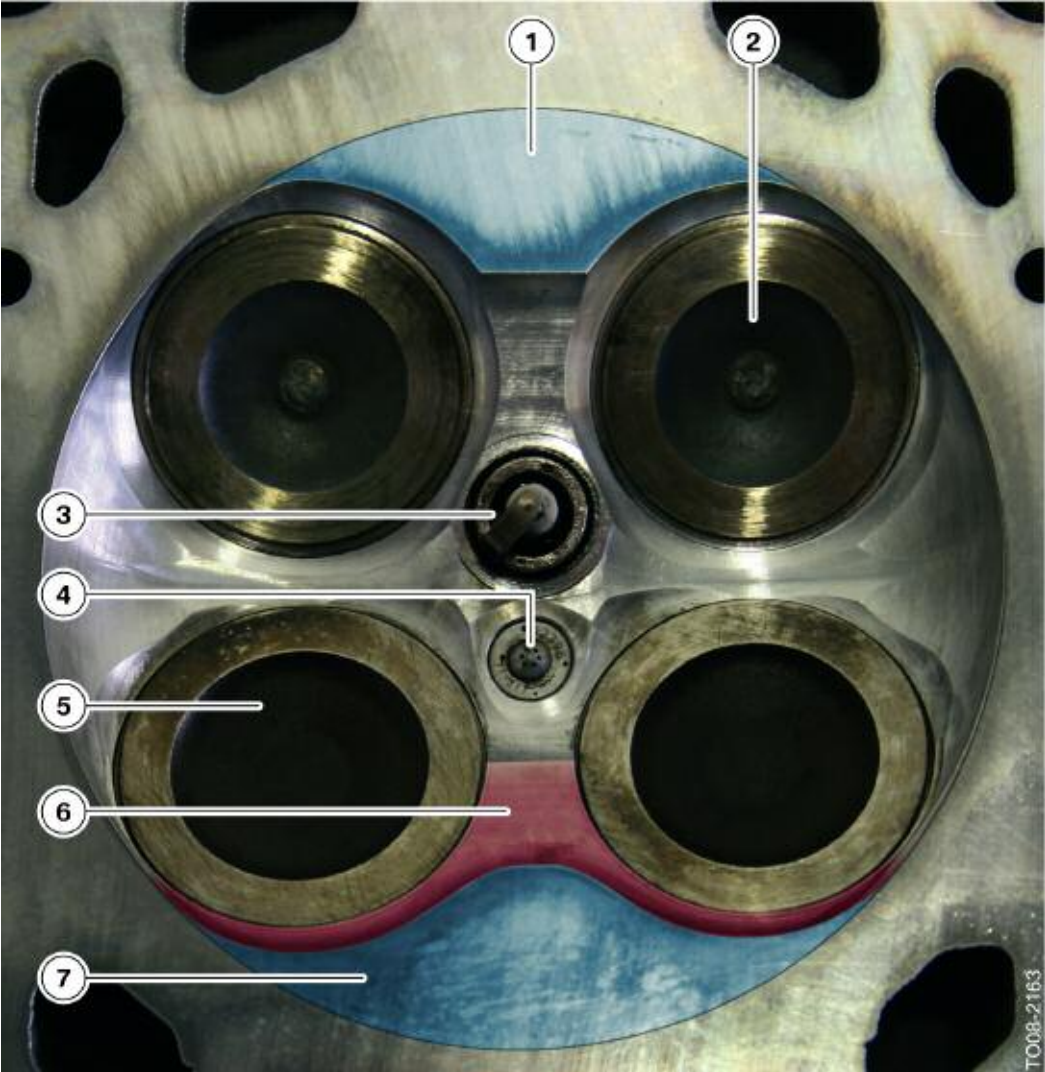

Index	Explanation
1	Quench area
2	Exhaust valves
3	Spark plug
4	Fuel injector
5	Intake valve
6	Masking
7	Quench area

The following graphic shows the effect of the previously described measures. These measures achieve improved and faster combustion in the red area. Technically, this is known as the turbulent kinetic energy.

**Influence of phasing and masking on flow in the combustion chamber**

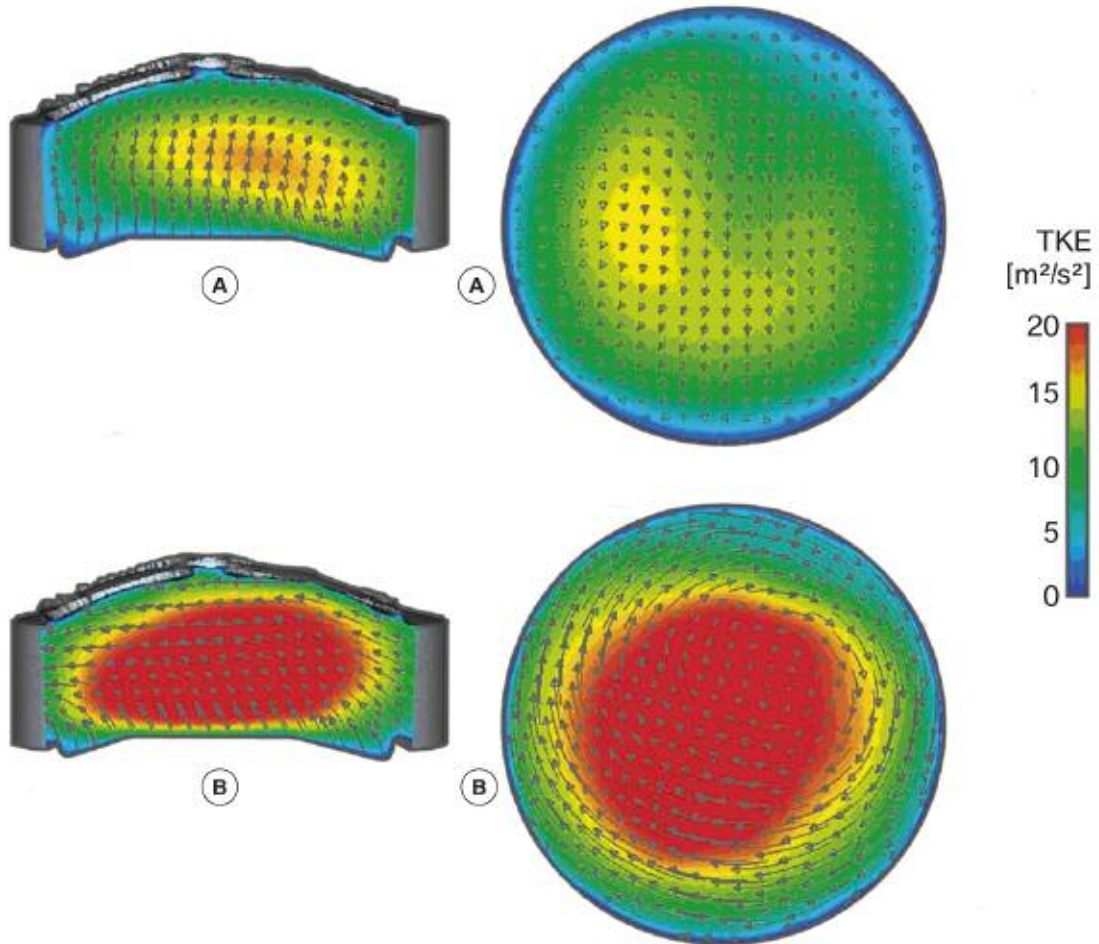

Index	Explanation
A	VALVETRONIC I
B	VALVETRONIC II and III with Phasing and masking
TKE	Turbulent kinetic energy

Engine response is improved by the combination of VALVETRONIC III, direct injection and turbocharging. The response up to naturally aspirated full load is shortened on a naturally aspirated engine with VALVETRONIC as there is now no need wait for the intake air manifold to be filled. The subsequent torque buildup as the turbocharger starts up can be accelerated with the partial lift setting at low engine speed. This effectively flushes out residual gas, thus resulting in faster torque build-up.

## Combustion Chamber Geometry

The following graphic shows the arrangement of the individual components in the combustion chamber. It can be seen that the BMW (spray-guided) high precision injection (HPI) system is not used but rather a Bosch solenoid valve fuel injector with multi-hole nozzle. The fuel injection is specially adapted to the combination of VALVETRONIC III and turbocharging. For better illustration, a set of valves has been removed in the graphic.

### N55, combustion chamber with components

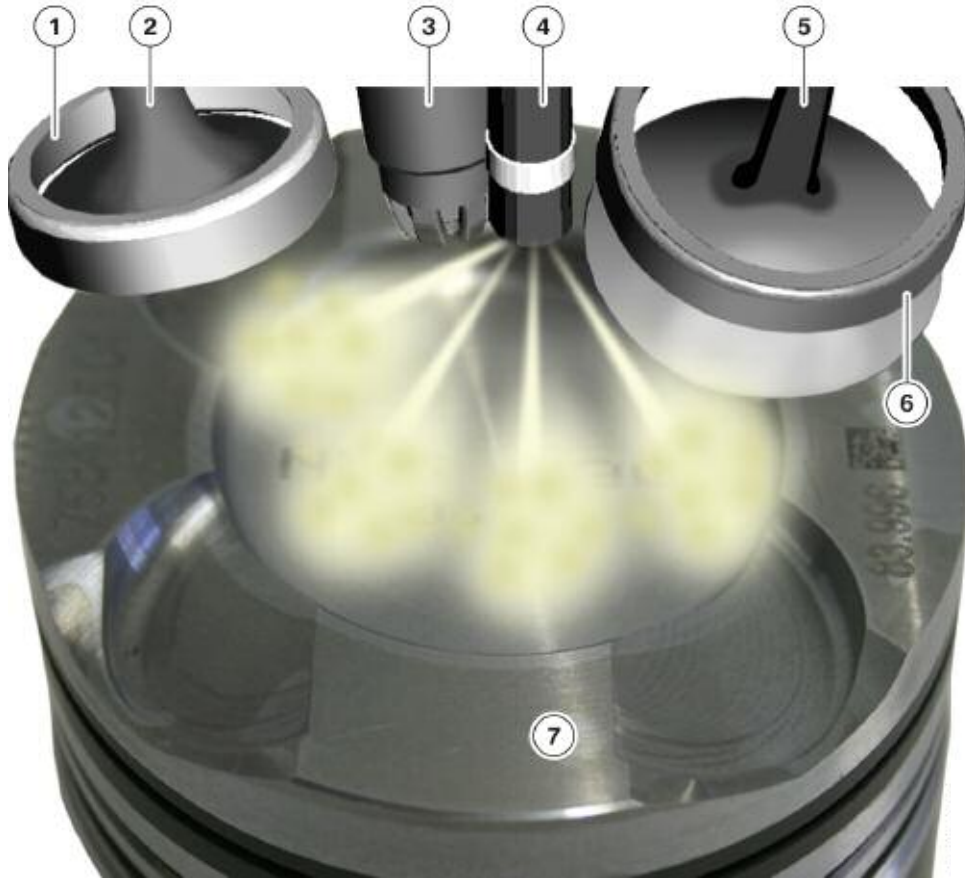

Index	Explanation
1	Valve seat, exhaust valve
2	Exhaust valve
3	Spark plug
4	Fuel injector
5	Intake valve
6	Valve seat, intake valve
7	Piston

### Valve Lift Adjustment Overview

As can be seen from the following graphic, the installation location of the servomotor has changed with VALVETRONIC III. Another new feature is that the eccentric shaft sensor is no longer mounted on the eccentric shaft but has been integrated into the servomotor.

#### N55, valve lift adjustment

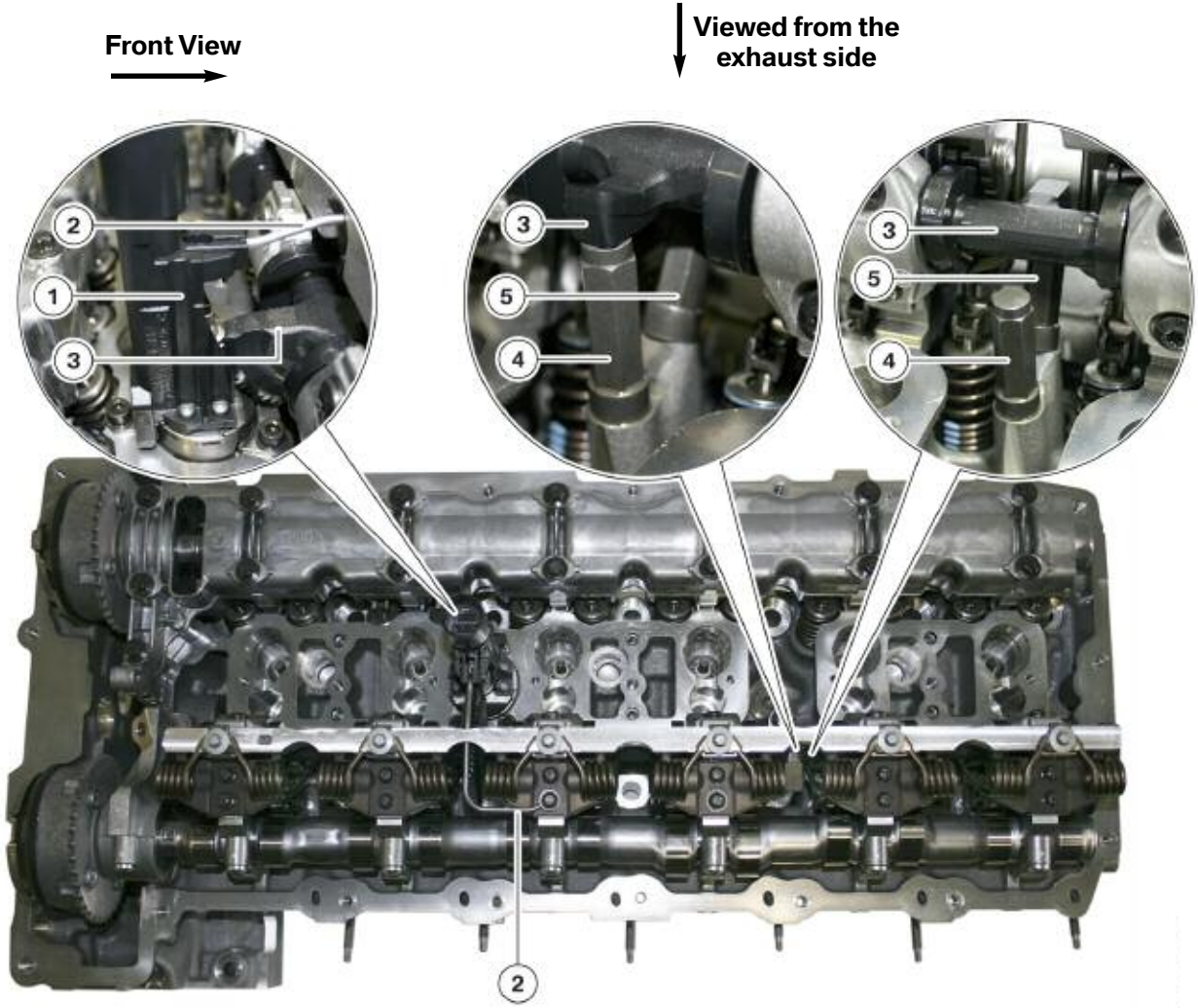

Index	Explanation
1	VALVETRONIC servomotor
2	Oil spray nozzle
3	Eccentric shaft
4	Eccentric shaft minimum stop
5	Eccentric shaft maximum stop

The VALVETRONIC III servomotor contains a sensor for determining the position of the motor and the eccentric shaft. The servomotor is lubricated with engine oil by means of an oil spray nozzle (1) aimed directly at the worm drive and the eccentric shaft mechanism.

**N55, design of valve lift adjustment**

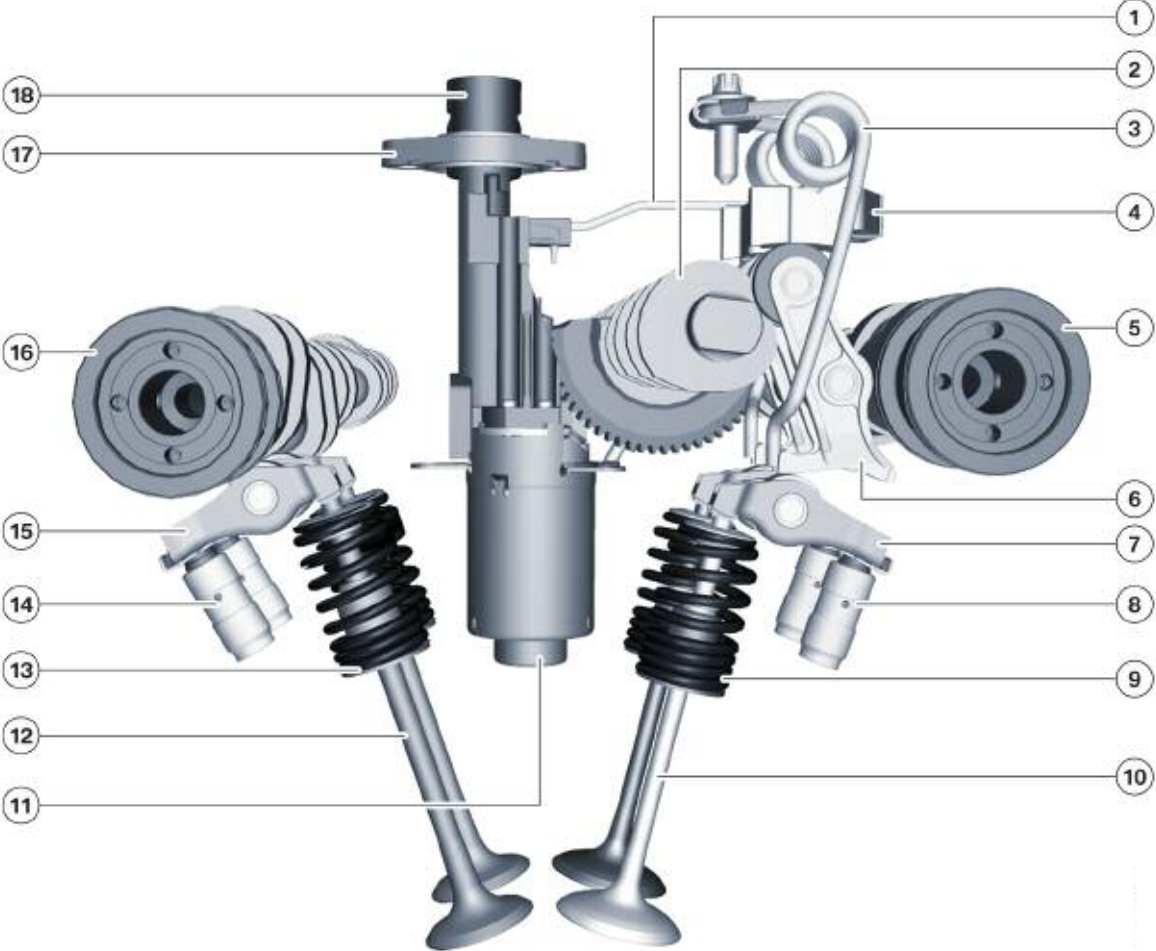

Index	Explanation	Index	Explanation
1	Oil spray nozzle	10	Intake valve
2	Eccentric shaft	11	VALVETRONIC servomotor
3	Return spring	12	Exhaust valve
4	Gate block	13	Valve spring
5	Inlet camshaft	14	Hydraulic valve lash adjustment
6	Intermediate lever	15	Roller cam follower, exhaust
7	Roller cam follower, intake	16	Exhaust camshaft
8	Hydraulic valve lash adjustment	17	Sealing sleeve
9	Valve spring	18	Socket



### ■ VALVETRONIC Servomotor

A brushless direct current motor (BLDC motor) is used. The BLCD motor is maintenance-free and very powerful, due to the contactless energy transfer system. The use of integrated electronic modules ensures precision control.

The VALVETRONIC servomotor has the following special features:

- Open concept (engine oil is directly supplied to the motor).
- The eccentric shaft angle is determined by angle increments from the integrated sensor system.
- Power consumption is reduced by about 50%.
- Higher actuating dynamics (e.g. cylinder-selective adjustment, idle speed control, etc.).
- Lightweight design is approximately 600 grams.

### ■ Function

Actuation of the VALVETRONIC servomotor is limited to a maximum of 40 amps. A maximum of 20 amps are available over a period of > 200 milliseconds. The VALVETRONIC servomotor is actuated by a pulse width modulated signal. The duty cycle is between 5% and 98%.

### VALVETRONIC Servomotor

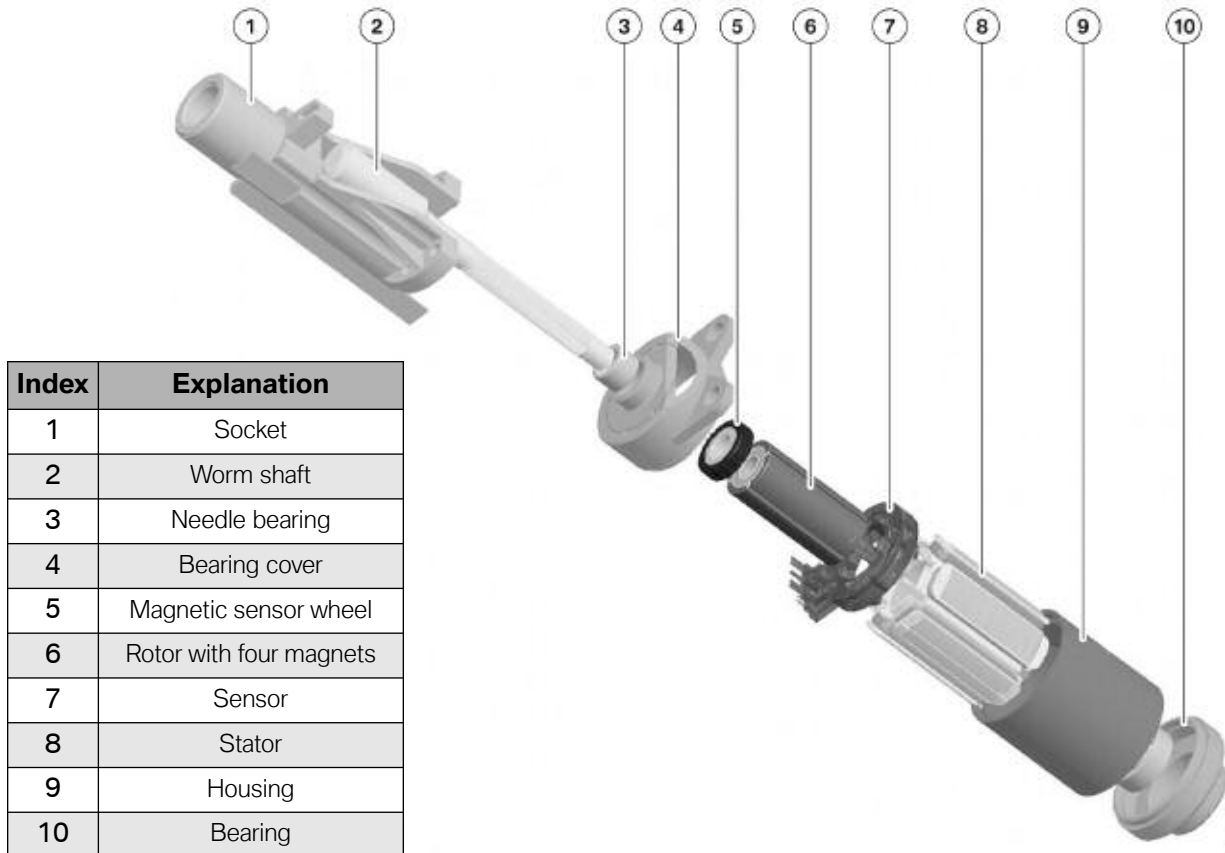

Index	Explanation
1	Socket
2	Worm shaft
3	Needle bearing
4	Bearing cover
5	Magnetic sensor wheel
6	Rotor with four magnets
7	Sensor
8	Stator
9	Housing
10	Bearing

# Belt Drive and Auxiliary Components

The belt drive has two deflection pulleys and one double ribbed belt.

## N55, Belt drive

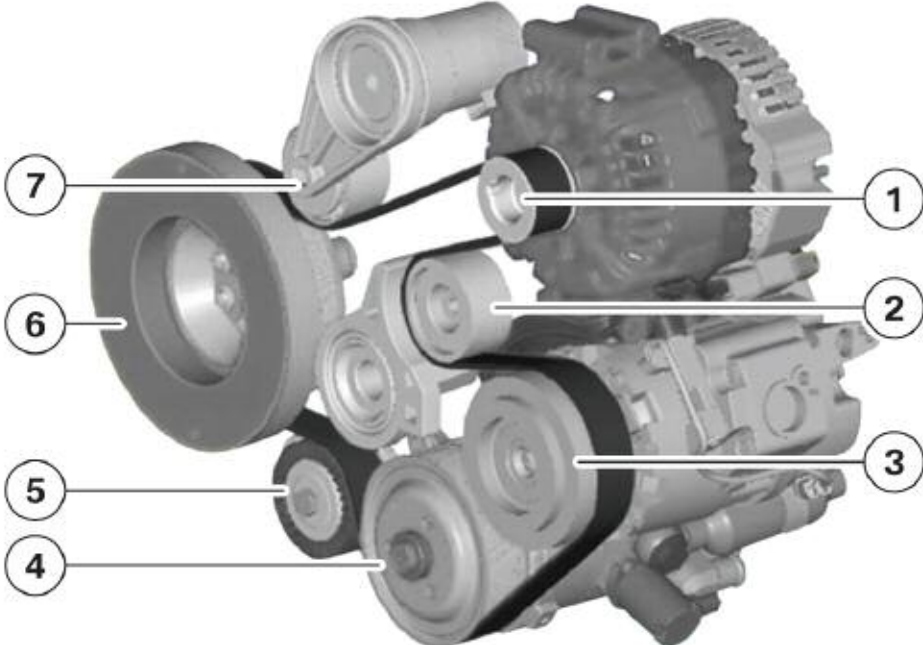

Index	Explanation	Index	Explanation
1	Belt pulley, alternator	5	Deflection pulley
2	Deflection pulley	6	Vibration absorber with belt pulley
3	Belt pulley, A/C compressor	7	Belt tensioner
4	Belt pulley, power steering pump		

# Vibration Damper

A single-mass vibration damper is used on the N55 engine. The belt pulley is mounted on the secondary pulley. Compared to the N54 engine, this design layout additionally reduces the belt load as the vulcanization decouples the belt pulley with flywheel mass from the crankshaft.

## N54, vibration damper

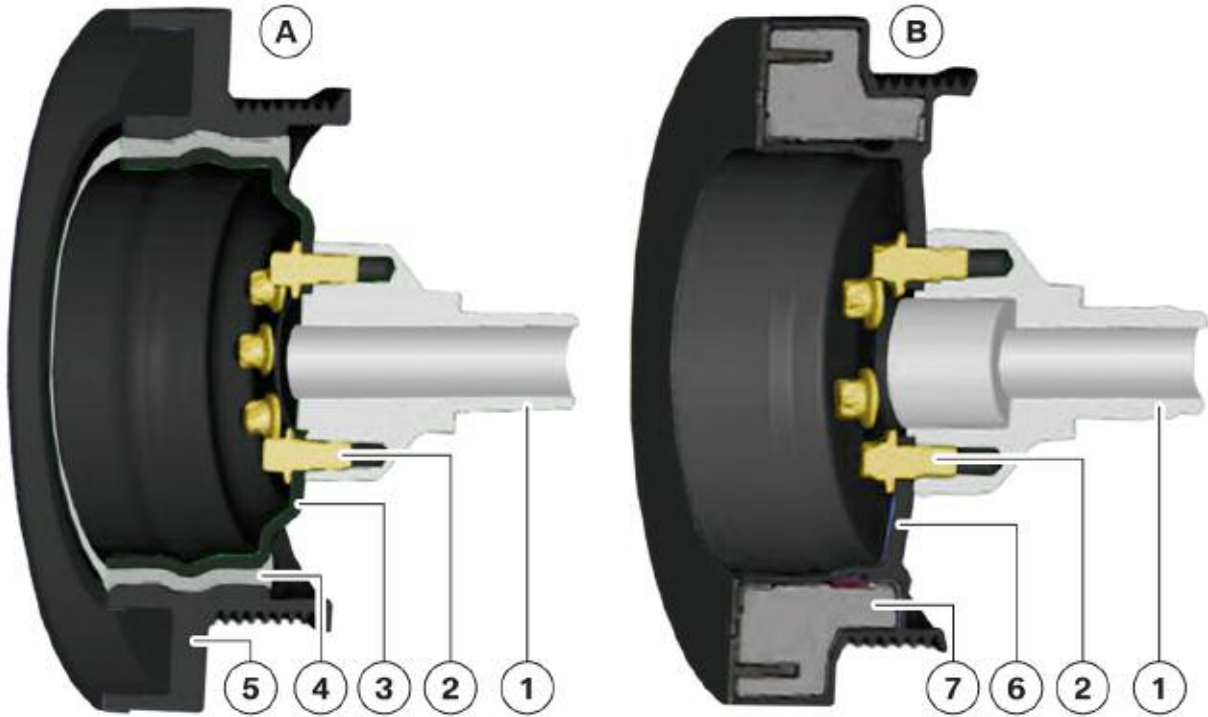

Index	Explanation
A	Vibration damper, N55 engine
B	Vibration damper, N54 engine
1	Crankshaft
2	Bolts
3	Primary pulley
4	Vulcanization
5	Secondary belt pulley with flywheel mass
6	Primary belt pulley
7	Flywheel mass

**N55, vibration damper**



Index	Explanation
1	Secondary belt pulley with flywheel mass
2	Flange
3	Vulcanization

# Air Intake and Exhaust System

## Air Intake System

Several functions of the air intake system have been optimized for the N55 engine:

- The unfiltered air is routed up to the intake silencer (similar to the N54 engine).
- The filtered air duct is completely new and simplified to accommodate the new turbocharger.
- The crankcase ventilation system has been redesigned.
- The diverter valve has been integrated into the compressor housing of the turbocharger.
- The fuel tank ventilation has been correspondingly adapted.

The design layout of the air intake system has been simplified, compared to the dual turbocharger set up of the N54.

**N55, Air Intake System**

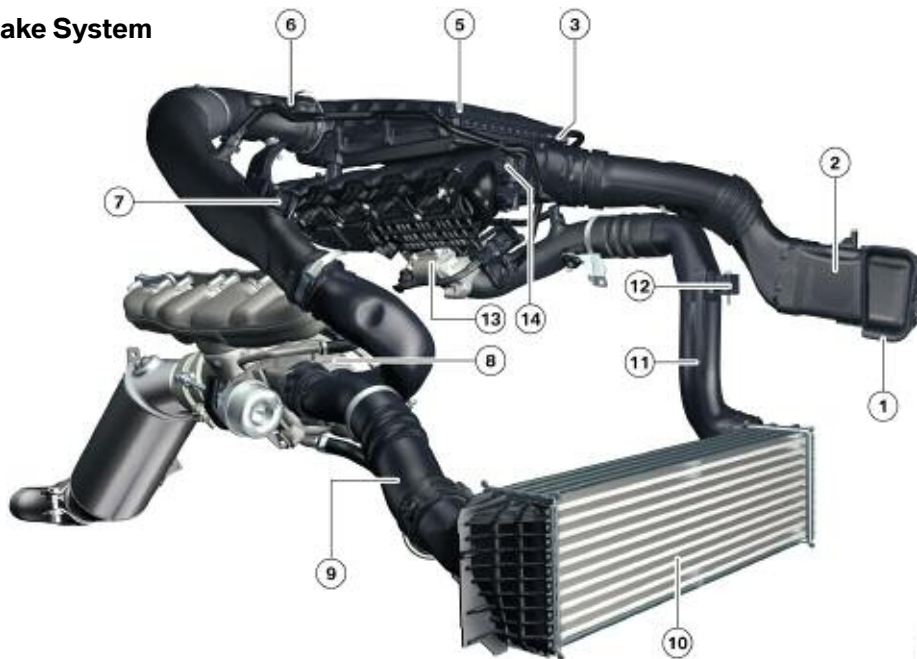

Index	Explanation	Index	Explanation
1	Intake snorkel	9	Charge-air pipe
2	Unfiltered air pipe	10	Intercooler
3	Intake silencer	11	Charge-air pipe
5	Air intake silencer cover	12	Boost pressure-temperature sensor
6	Hot-film air mass meter	13	Throttle valve
7	Crankcase ventilation connection	14	Intake manifold
8	Exhaust turbocharger		

**N55, Air Intake and Exhaust System**

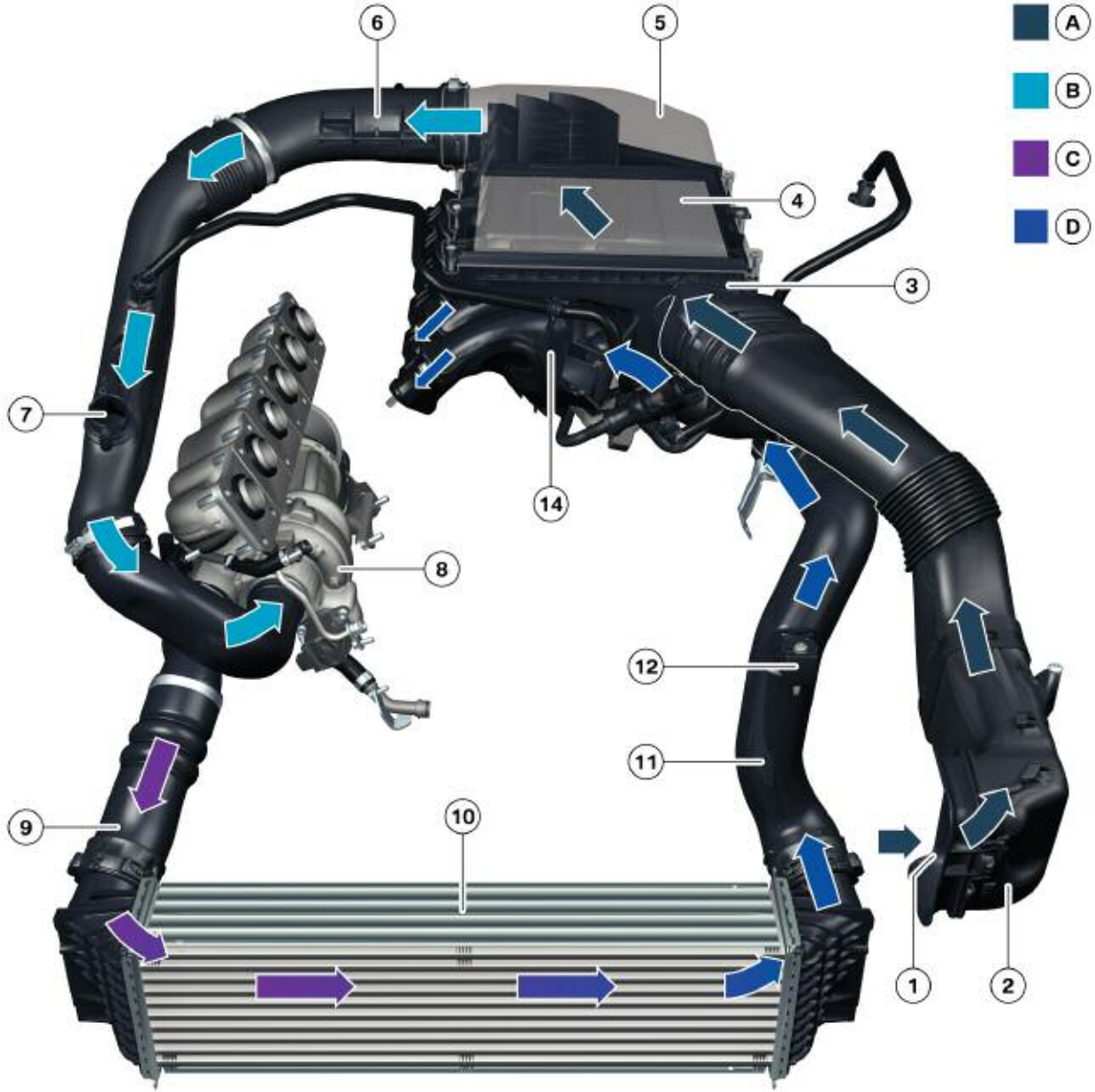

<b>Index</b>	<b>Explanation</b>
A	Unfiltered air
B	Purified air
C	Heated charge air
D	Cooled charge air
1	Intake snorkel
2	Unfiltered air pipe
3	Intake silencer
4	Filter element
5	Air intake silencer cover
6	Hot-film air mass meter
7	Crankcase ventilation connection
8	Exhaust turbocharger
9	Charge-air pipe
10	Intercooler
11	Charge air pipe
12	Boost pressure-temperature sensor
14	Intake air manifold

# Intake Manifold

The engine control unit is mounted on the intake manifold. The intake air is used to cool the engine control unit.

Thanks to this arrangement, the engine comes down the assembly line completely assembled with the control unit, the sensors, and actuators already connected.

## N55, intake system with DME control unit

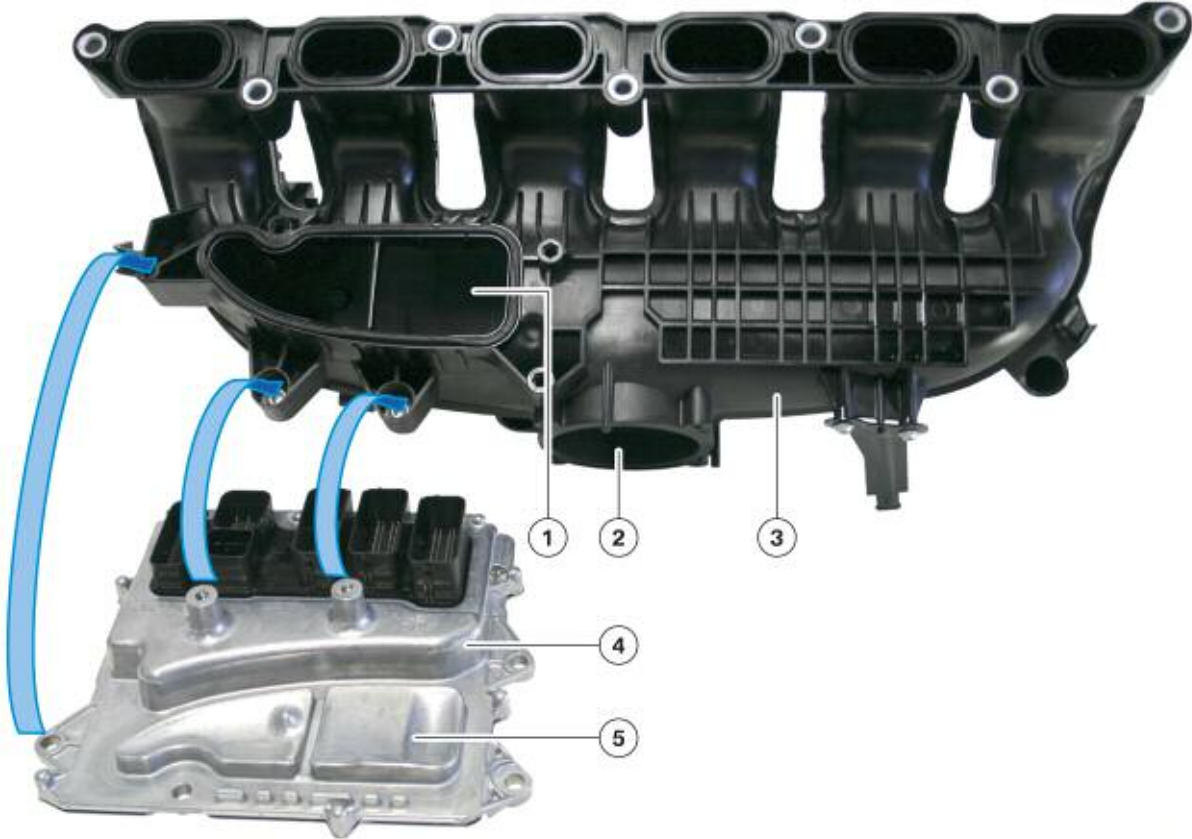

Index	Explanation	Index	Explanation
1	Mounting flange for engine control unit cooling	4	Engine control unit
2	Mounting flange for throttle valve	5	Cooling fins
3	Air intake system		



## Fuel Tank Ventilation System

The fuel vapors are stored in a charcoal canister and then fed via the fuel tank vent valve to the combustion process. It was also necessary to adapt this system to all the given conditions related to turbocharging.

### N55, fuel tank ventilation system



Index	Explanation
1	Connection to ventilation line from charcoal canister
2	Connection upstream of throttle valve
3	Fuel tank vent valve
4	Connection downstream of throttle valve
5	Connection upstream of turbocharger

## Exhaust Manifold

The exhaust manifold is air-gap insulated and designed as a six ports into two chamber manifold. Dividing six exhaust ports into two exhaust chambers is necessary in order to ensure optimum flow to the twin scroll turbocharger. The exhaust pulses from the first three cylinders (1-3) feed one scroll (duct 1) of the turbo, while the last three (4-6) feed the second scroll (duct 2). The exhaust manifold and turbocharger are welded together to form one component.

### N55, attachment of exhaust manifold and turbocharger to engine block

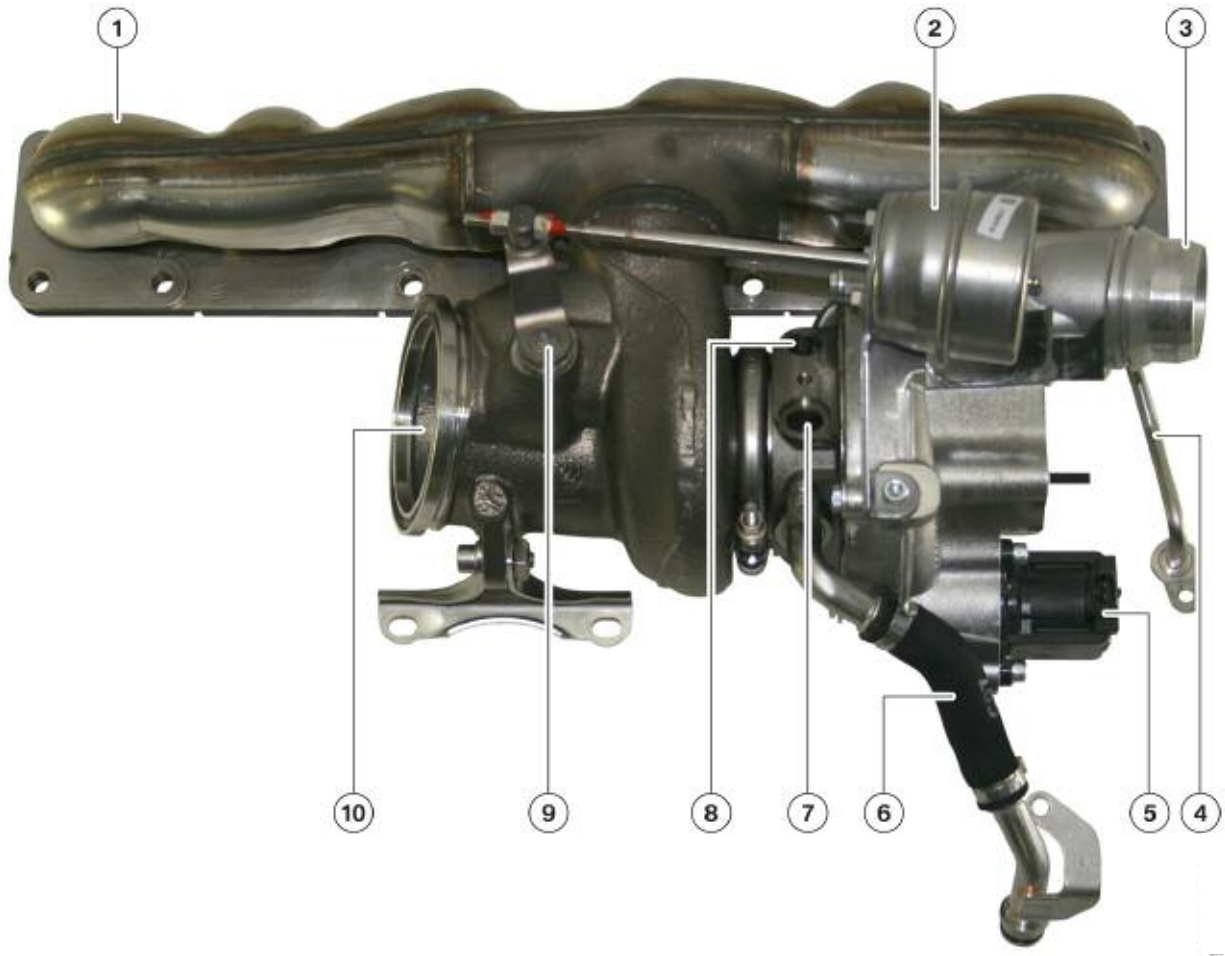

Index	Explanation	Index	Explanation
1	Exhaust manifold	6	Oil return line
2	Vacuum unit	7	Coolant infeed
3	Connection to intercooler	8	Coolant return
4	Oil feed line	9	Shaft, wastegate valve
5	Diverter valve	10	Connection to exhaust system

# Turbocharger

The N55 is equipped with a single twin scroll turbocharger instead of two separate small turbochargers as on the N54 engine. The following graphics show the operating principle of the twin scroll turbocharger.

## Twin scroll turbocharger rear view

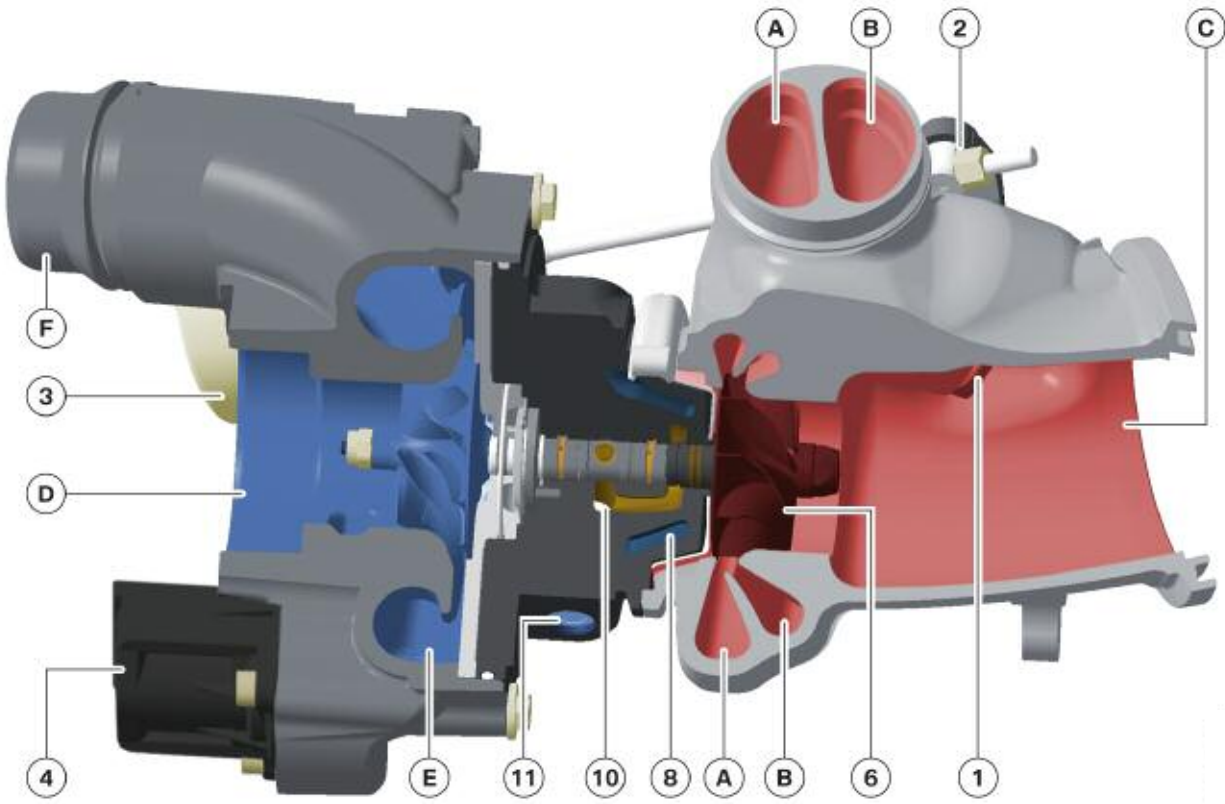

Index	Explanation	Index	Explanation
A	Exhaust duct 1 (cylinders 1 - 3)	2	Lever arm, wastegate valve
B	Exhaust duct 2 (cylinders 4 - 6)	3	Vacuum unit for wastegate valve
C	Connection to catalytic converter	4	Diverter valve
D	Inlet from intake silencer	6	Turbine wheel
E	Ring channel	8	Cooling duct
F	Outlet to intercooler	10	Oil return
1	Wastegate valve	11	Coolant return

---

## **Function of the Twin Scroll Turbocharger**

The system is designed so that constant exhaust gas pressure is rarely applied to the turbocharger. At low engine speeds, the exhaust reaches the turbine in tuned pulsed form. Due to this pulsation, a higher pressure ratio is temporarily reached in the turbine. Since the efficiency increases as the pressure rises, the pulsation improves the boost pressure progression and thus the torque progression of the engine. This is the case particularly at low engine speeds.

To limit the back pressure and ensure that the individual cylinders do not mutually influence each other during the cylinder charging process, cylinders 1 - 3 (bank 1) and cylinders 4 - 6 (bank 2) are combined to form two exhaust channels. The exhaust gas pulses in the exhaust channels (1 and 2) are directed into two scrolls (spirals) within the turbocharger to drive the turbine wheel. This design layout makes it possible to optimally use the exhaust pulsations for generating boost pressure based on the firing order of the engine. This improves engine efficiency by enhancing throttle response and limiting unwanted turbo lag.

The wastegate valve is used for the purpose of limiting the boost pressure and is already known from previous BMW turbo engines. It is vacuum operated and electronically controlled through a vacuum control solenoid by the DME (ECM).

## **Diverter Valve**

The basic function of the diverter valve remains the same. The difference compared to the N54 engine is that the diverter valve is not operated pneumatically. The diverter valve on the N55 engine is an electric actuator that is controlled directly by the DME. The number of components has been greatly reduced by positioning the diverter valve on the turbocharger compressor housing.

The diverter valve is designed to release unwanted pressure in the intake by connecting the pressure side of the induction system to the inlet side under deceleration. The undesirable peaks in the boost pressure that can occur when the throttle valve is quickly closed are reduced. This means the diverter valve plays an important role in terms of the engine acoustics while protecting the components of the turbocharger.

## Catalytic Converter

Two ceramic honeycomb structures are contained in the catalytic converter housing. The catalytic converter has a volume of 2.7 liters. Depending on the type of vehicle the ceramic structures have different coatings.

Ceramic structure 1 has a volume of 1.2 liters, a diameter of 125 mm, and contains 600 cells.

Ceramic structure 2 has a volume of 1.5 liters, a diameter of 125 mm, and contains 400 cells.

### N55, catalytic converter

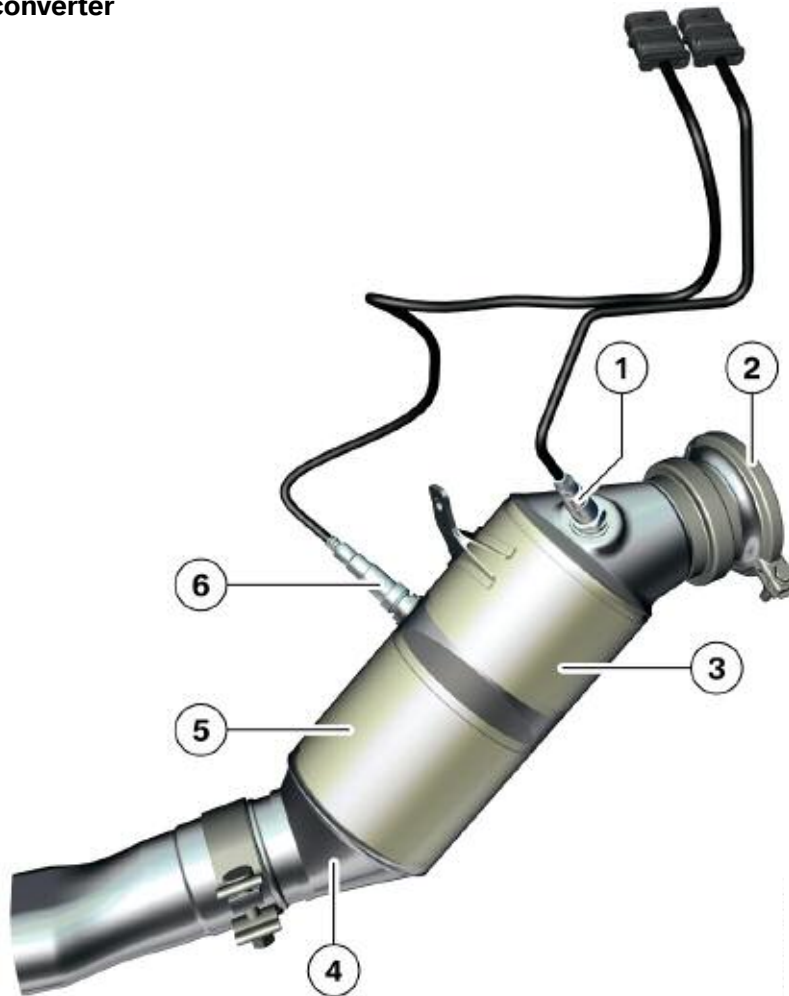

Index	Explanation	Index	Explanation
1	Oxygen sensor upstream of catalytic converter	4	Catalytic converter outlet funnel
2	Connection to the turbocharger	5	Ceramic structure 2
3	Ceramic structure 1	6	Oxygen sensor after ceramic structure 1

## Exhaust System

With the single twin scroll turbocharger, the design of the exhaust system is less complicated than that of the N54 engine, with two turbochargers. In addition to a “near-engine” catalytic converter design, the exhaust system also features a center silencer and two rear silencers.

### N55, exhaust system F07



Index	Explanation
1	Exhaust manifold
2	Exhaust turbocharger
3	Catalytic converter
4	Center silencer
5	Rear silencer, right
6	Rear silencer, left

**Note:** Due to the high efficiency of the “near engine” three way catalytic converter, no additional catalytic converters are necessary.

# Vacuum System

The N55 engine is equipped with a vacuum pump for generating the vacuum required by the brake booster and the auxiliary consumers (exhaust flaps and wastegate). A vacuum accumulator (built into the cylinder head cover) is used to ensure there is sufficient vacuum for the wastegate valve at all times.

## N55, vacuum system

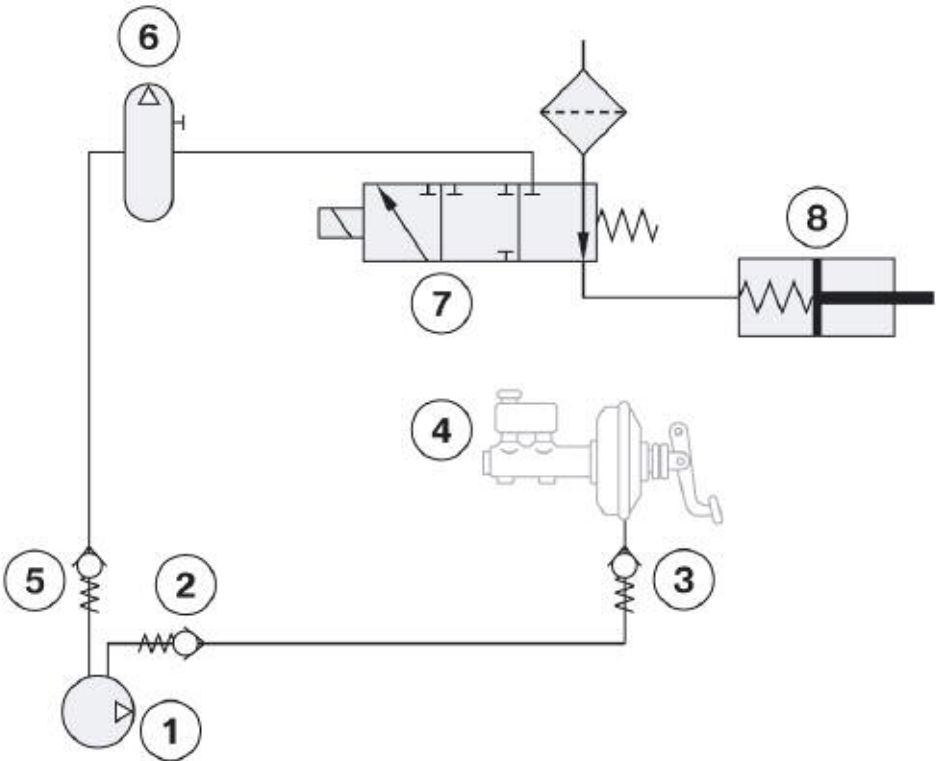

Index	Explanation	Index	Explanation
1	Vacuum pump	5	Non-return valve
2	Non-return valve	6	Vacuum accumulator (Integrated into the cylinder head cover)
3	Non-return valve	7	Electropneumatic pressure converter (Vacuum solenoid)
4	Brake servo unit	8	Vacuum unit, wastegate valve

## Vacuum Pump

The vacuum pump is similar to that used on the N63 engine. It is a two-stage pump and therefore has two connections. The first stage is for the brake booster and the second for the auxiliary consumers.

### N55, vacuum pump

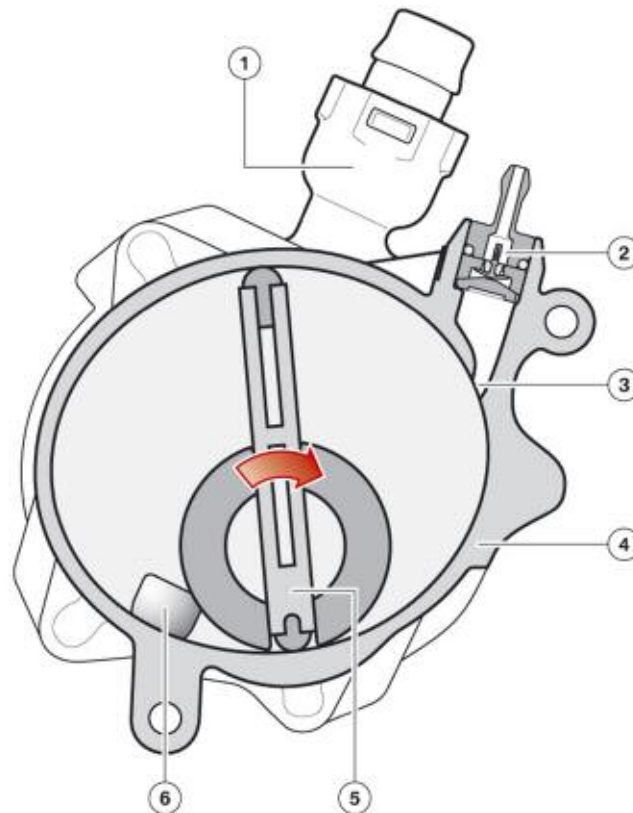

Index	Explanation
1	Non-return valve for brake booster
2	Non-return valve for auxiliary consumer
3	Connection opening for auxiliary consumers
4	Vacuum pump housing
5	Vane
6	Connection opening for brake booster

The largest area is used for the first stage, ensuring vacuum is built up at a rapid rate for the brake booster. The last section is the opening stage for the auxiliary consumers. It therefore takes longer to build up the vacuum here, as shown in the following diagram.



This solution takes into account the different requirements for the brake booster and the auxiliary consumers.

**N55, delivery rate of the two-stage vacuum pump**

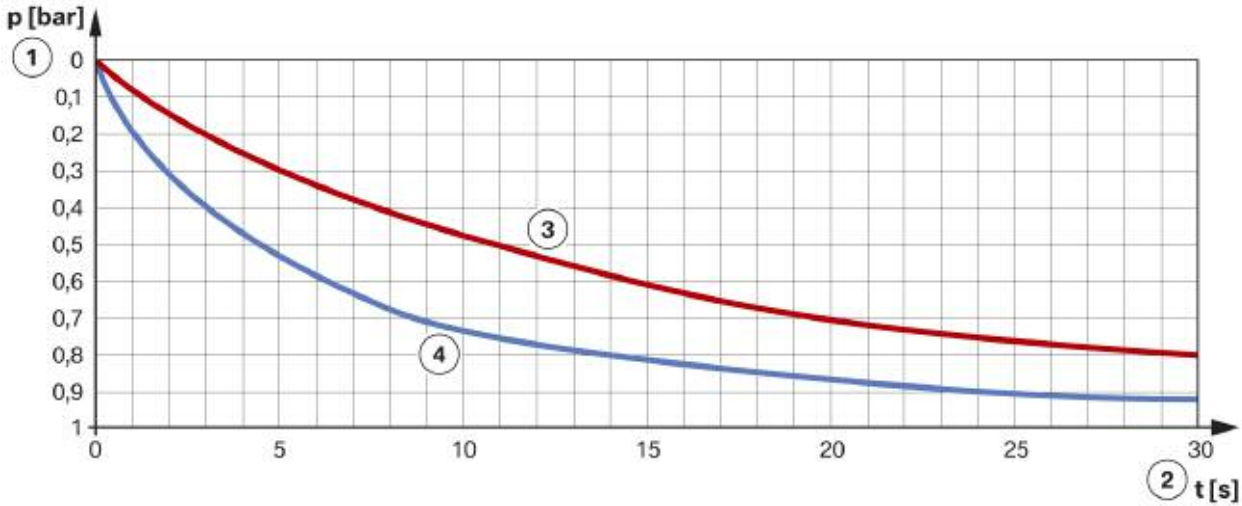

Index	Explanation
1	Vacuum
2	Time
3	Delivery rate for auxiliary consumers
4	Delivery rate for brake booster

# Fuel System

## Fuel Injection

The high pressure fuel injection system (HDE) is used on the N55 engine. In contrast to high precision injection (HPI), HDE uses solenoid fuel injectors with multi-hole nozzles.

The following overview shows the complete fuel injection system. The system is similar to the N54 fuel injection. Although the same high pressure pump, pressure sensor, and fuel rail are used, the high pressure fuel injection valves are new. The HDE system uses Bosch high pressure solenoid type fuel injection valves with the designation HDEV5.2.

### N55, overview of high pressure fuel injection system

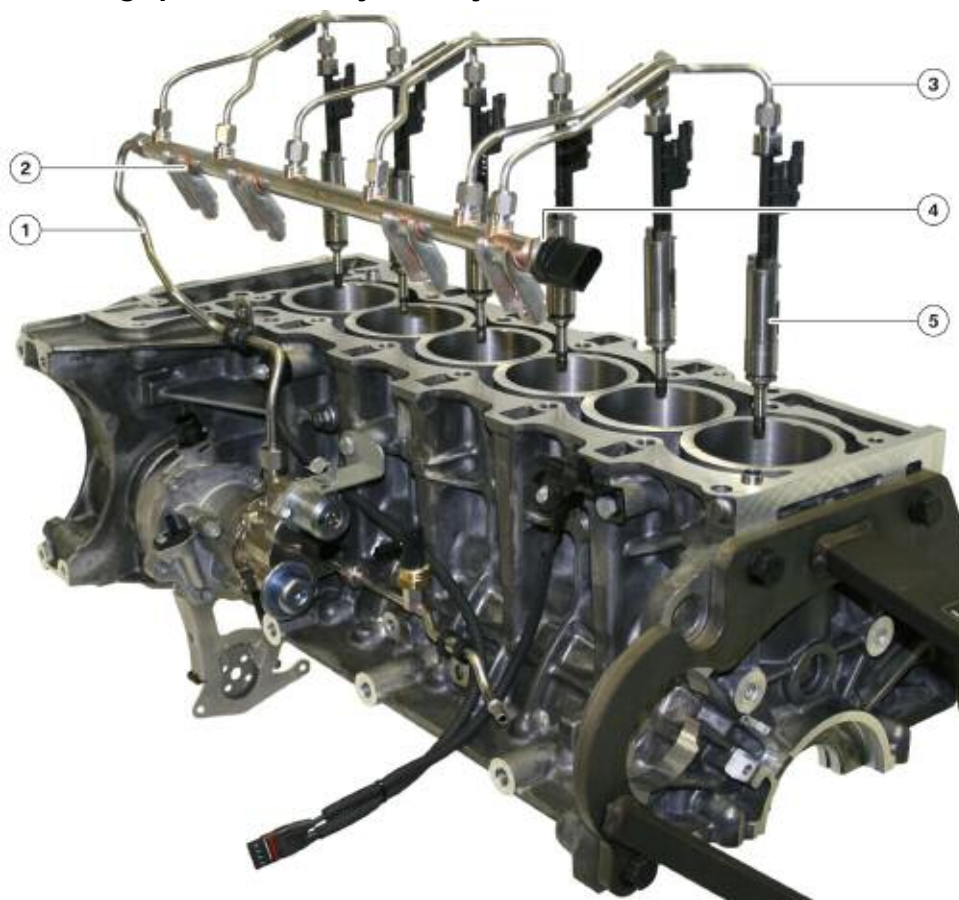

Index	Explanation
1	High pressure line
2	Rail
3	High pressure line
4	Fuel rail pressure sensor
5	Solenoid valve fuel injector

## Fuel Pressure Sensor

The fuel is supplied at a primary pressure of 5 bar by the electric fuel pump from the fuel tank via the supply line to the high pressure pump. The primary pressure is monitored by the fuel pressure sensor (5). The fuel is delivered by the electric fuel pump corresponding to engine requirements. The fuel pressure sensor known from the N54 and N63 is used.

In the event of the fuel pressure sensor failing, the electric fuel pump continues operation at 100% delivery rate as from terminal 15 ON.

## N55 Engine

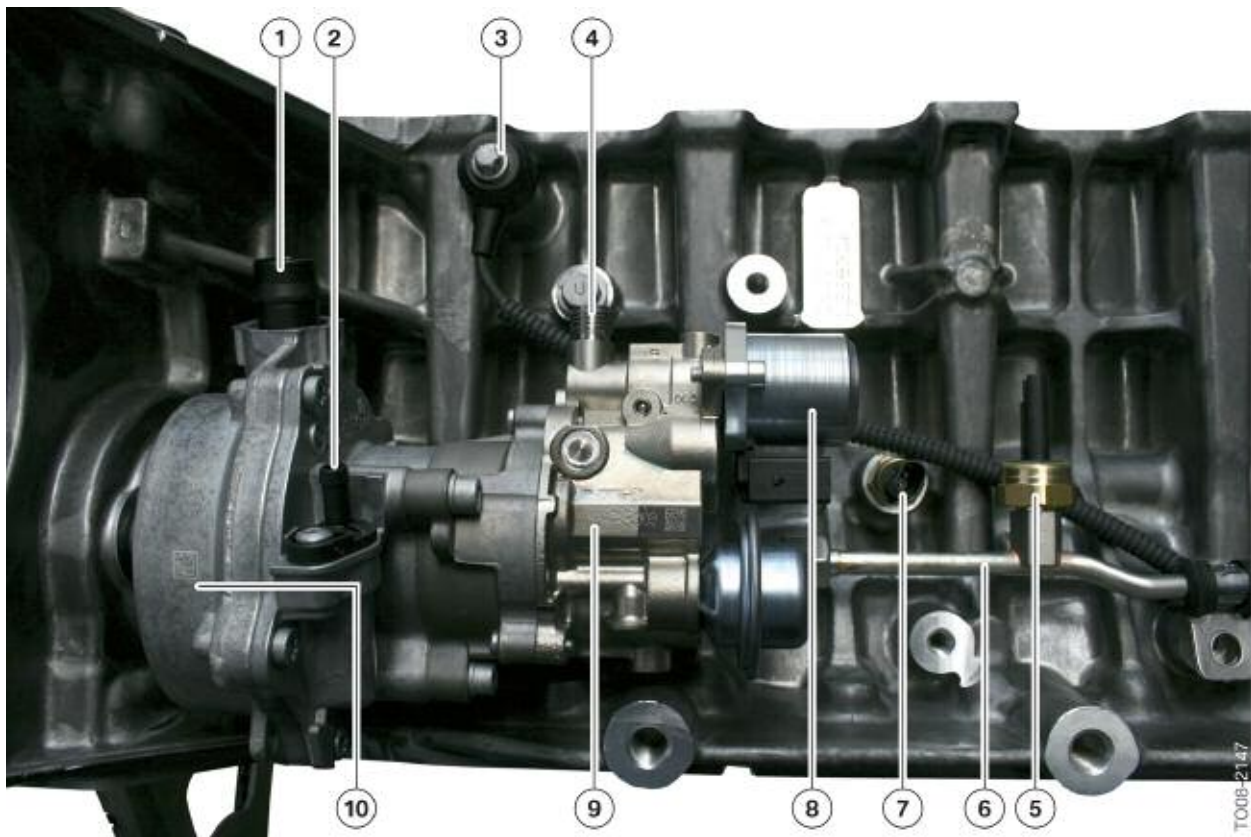

Index	Explanation	Index	Explanation
1	Non-return valve for brake booster	6	Fuel supply line
2	Non-return valve for auxiliary consumers	7	Oil pressure sensor
3	Knock sensor	8	Quantity control valve
4	Connection, high pressure line to fuel rail	9	High pressure pump
5	Fuel pressure sensor	10	Vacuum pump

## High Pressure Fuel Pump

The fuel is pressurized in the permanently driven three-piston high pressure pump and delivered to the fuel rail via the high pressure line. The fuel stored under pressure in the fuel rail is distributed via the high pressure lines to the high pressure fuel injection valves. The required fuel pressure is determined by the engine management as a function of the engine load and engine speed. The pressure level is registered by the rail pressure sensor and sent to the engine control unit. The fuel is regulated by the quantity control valve based on a target/actual value comparison of the rail pressure. The pressure level is configured such to achieve the smoothest running properties with the best possible fuel consumption. A pressure of 200 bar is only required at high load and low engine speed. The high pressure pump is of the same design as the high pressure pump used on the N54 engine.

### N55, fuel pressure diagram

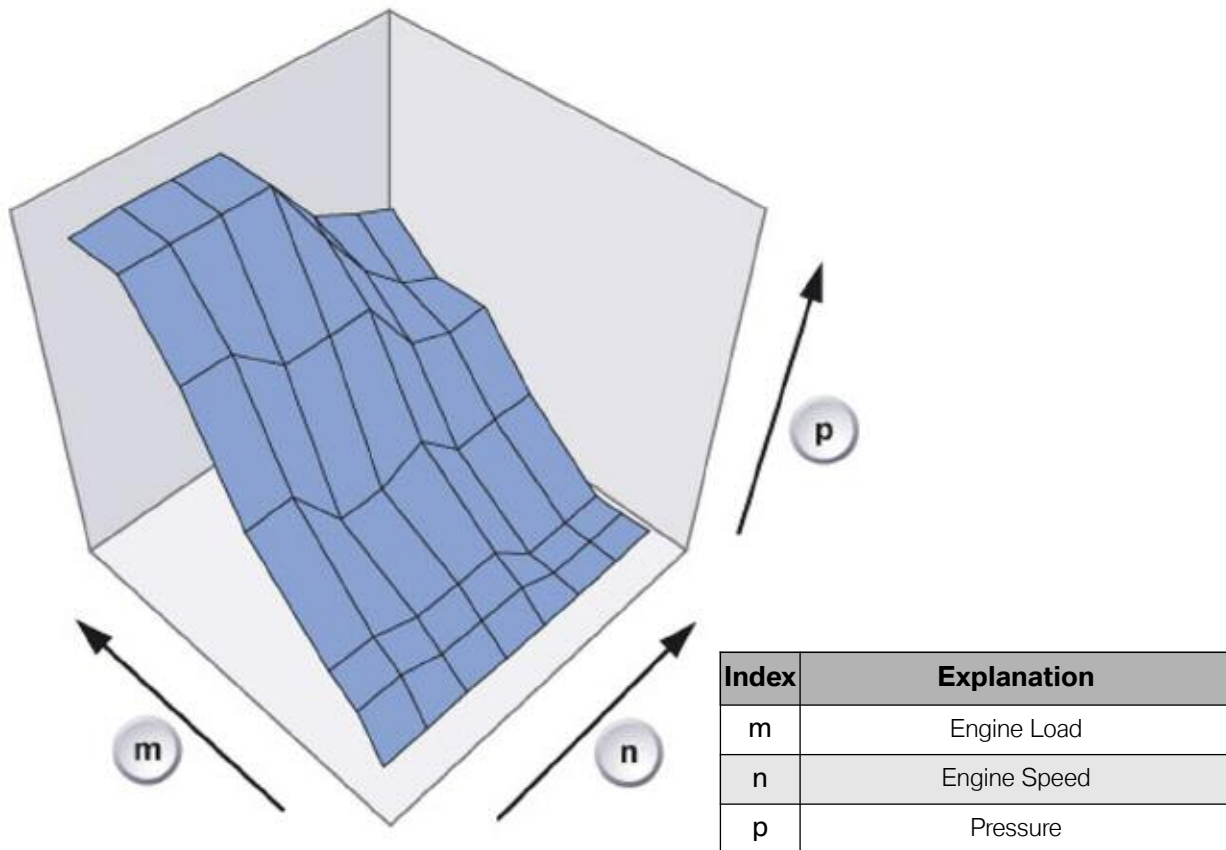

---

## Fuel Injectors

The high pressure fuel injection valve Bosch HDEV5.2 is a solenoid type injector. In contrast to the piezo-electric injectors used on the current BMW engines, the solenoid valve fuel injectors are designed as inward-opening multi-hole valves with highly variable jet angle and form. They operate at a system pressure of up to 200 bar.

**CAUTION!!!**

**Do not open the fuel system if the coolant temperature is above 40°C/104°F. The residual pressure in the high pressure fuel system could cause bodily injury.**

It is essential to observe the utmost cleanliness when working on the high pressure fuel system and to follow the proper working procedures described in the repair instructions. Even minute soiling or damage at the thread connections of the high pressure lines could cause leaks.

**Note: Special tool # 13 0 270 must be used to remove the HDEV5.2 high pressure injector valves from the engine. Damage to the injector or the related components may occur otherwise. See the Service Information section in this training material for more information.**

Particular care must be taken when working on the fuel system of the N55 engine to ensure that the ignition coils are not wet with fuel. The resistance of the silicone insulating material of the coils is greatly reduced by the contact with fuel. This could result in arcking at the top of the spark plug and misfiring. See the Service Information section and repair instructions for more information.

# Cooling System

The cooling system of the N55 is enhanced with additional oil cooling.

Two different types of oil cooling systems are used depending on the model and application. In the “hot climate” version, heat transfer from the engine oil to the engine coolant is avoided by separating the oil cooler from the engine coolant circuit. The other version uses an auxiliary radiator in combination with an oil to coolant heat exchanger bolted to the oil filter housing. The auxiliary radiator enhances cooling efficiency by adding surface area to the cooling system.

## N55, cooling system

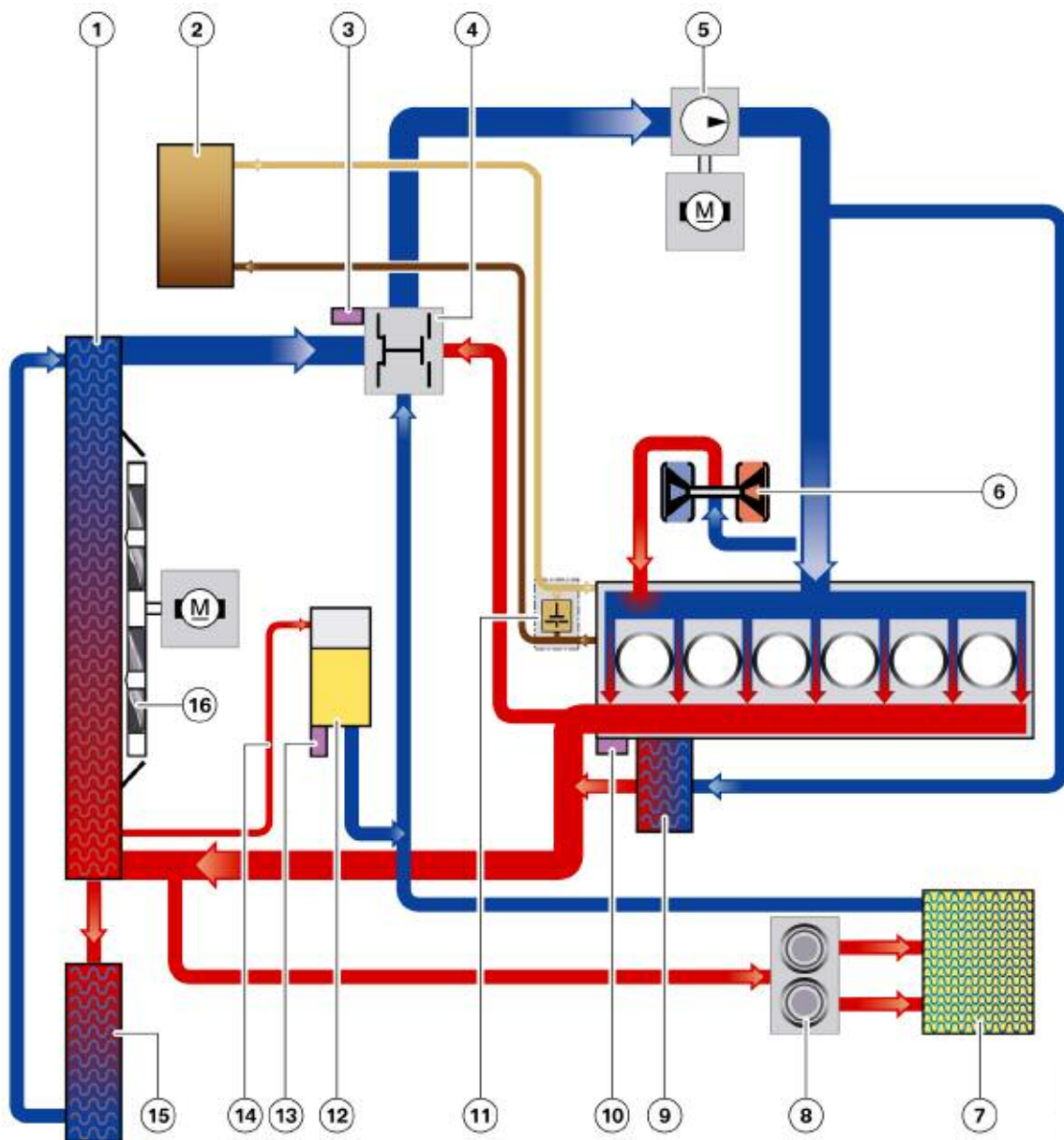

---

### Legend for N55 cooling system

Index	Explanation
1	Radiator
2	Engine oil to air cooler (hot climate version)
3	Heater coil
4	Characteristic map thermostat
5	Electric coolant pump
6	Exhaust turbocharger
7	Heating heat exchanger
8	Coolant valve
9	Oil-to-coolant heat exchanger
10	Coolant temperature sensor
11	Engine oil thermostat (hot climate version)
12	Expansion tank
13	Coolant level switch
14	Equalization line
15	Auxiliary radiator
16	Electric fan

## Components

### N55, Cooling System Components

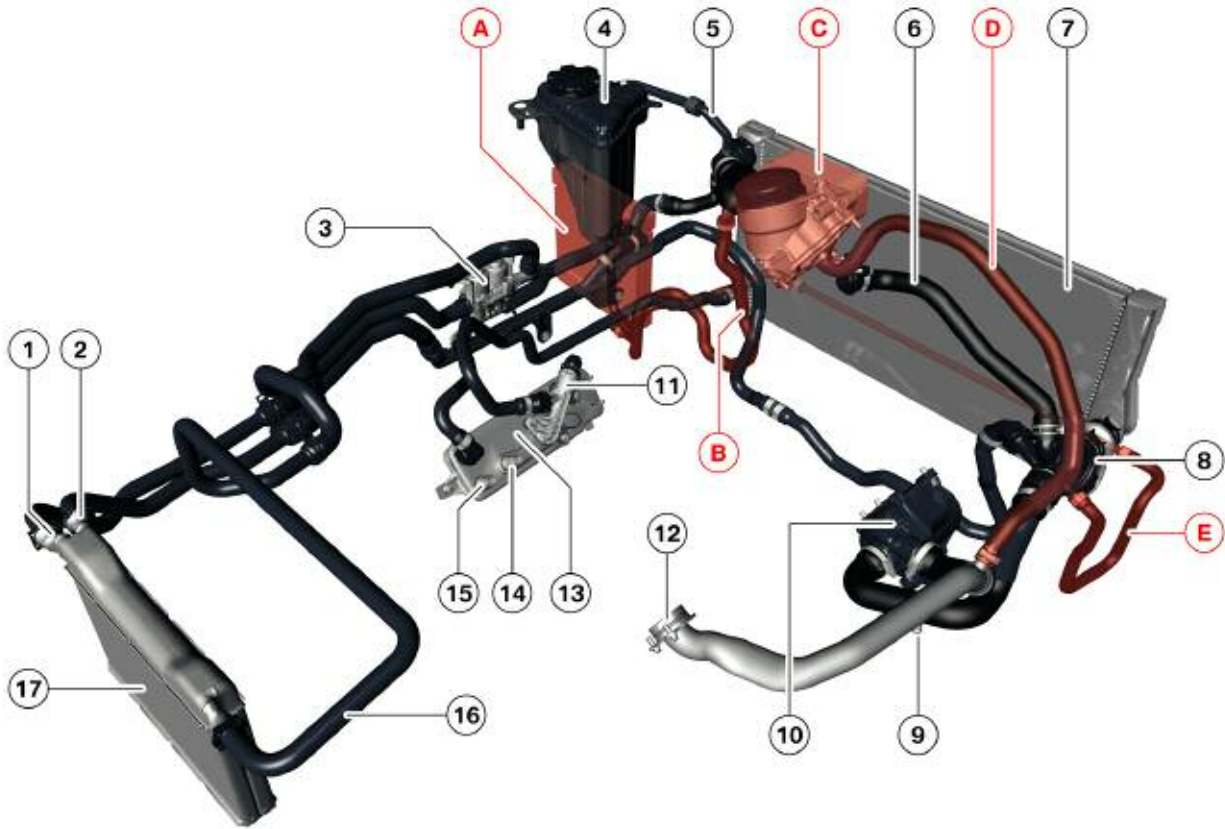

Index	Explanation	Index	Explanation
A	Auxiliary radiator	7	Bypass line for small cooling circuit
B	Coolant feed line to auxiliary radiator	8	Thermostat
C	Oil-to-coolant heat exchanger	9	Electric coolant pump
D	Coolant feed line to oil-to-coolant heat exchanger	10	Exhaust turbocharger supply line
E	Coolant return line from auxiliary radiator	11	Thermostat for transmission oil cooling
1	Zone 1 feed line, heating heat exchanger	12	Coolant feed line to engine block
2	Zone 2 feed line, heating heat exchanger	14	Transmission oil-to-coolant heat exchanger
3	Coolant valve	15	Connection, transmission oil line
4	Expansion tank	16	Connection, transmission oil line
5	Equalization line	17	Return, heating heat exchanger
6	Radiator		



The following graphic shows the connection of the auxiliary radiator to the cooling system. The auxiliary radiator is connected to the radiator by means of parallel coolant lines, thus increasing the cooling surface area. This system is combined with an oil-to-coolant heat exchanger mounted on the oil filter housing. (See component “C” in the previous graphic.)

**N55, auxiliary radiator**

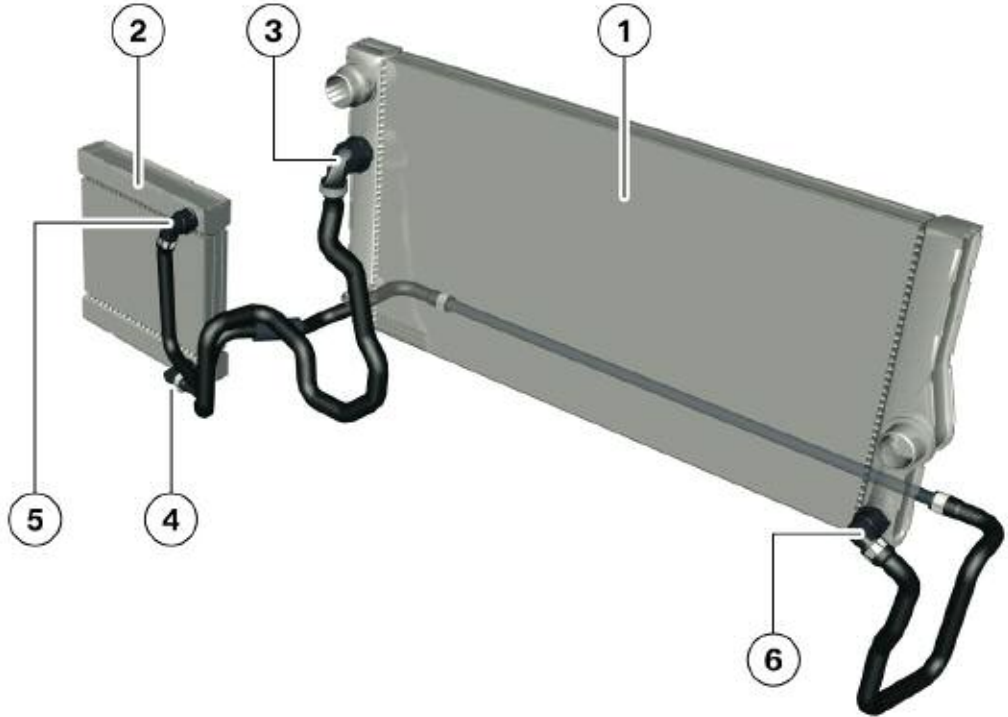

Index	Explanation
1	Radiator
2	Auxiliary Radiator
3	Feed connection to the auxiliary radiator
4	Feed connection at the auxiliary radiator
5	Return connection to the auxiliary radiator
6	Return connection from the auxiliary radiator



**If a separate oil to air cooler is not installed, an auxiliary radiator in conjunction with an oil to coolant heat exchanger is used to cool the engine oil.**

# Oil Cooler

N55, engine oil cooling, "hot climate"



Index	Explanation
1	Oil filter module
2	Thermostat
3	Oil cooler lines
4	Engine oil to air heat exchanger (oil cooler)



**Most current US vehicles use a separate engine oil to air heat exchanger to cool the engine oil (hot climate version).**

# Coolant Passages

The coolant passages in the cylinder head are also used for indirect cooling of the fuel injectors. The following graphic clearly shows that the coolant flows over the valves and the fuel injectors, thus reducing the heat transfer to the components to a minimum.

**N55, casting of the coolant passages in cylinder head**

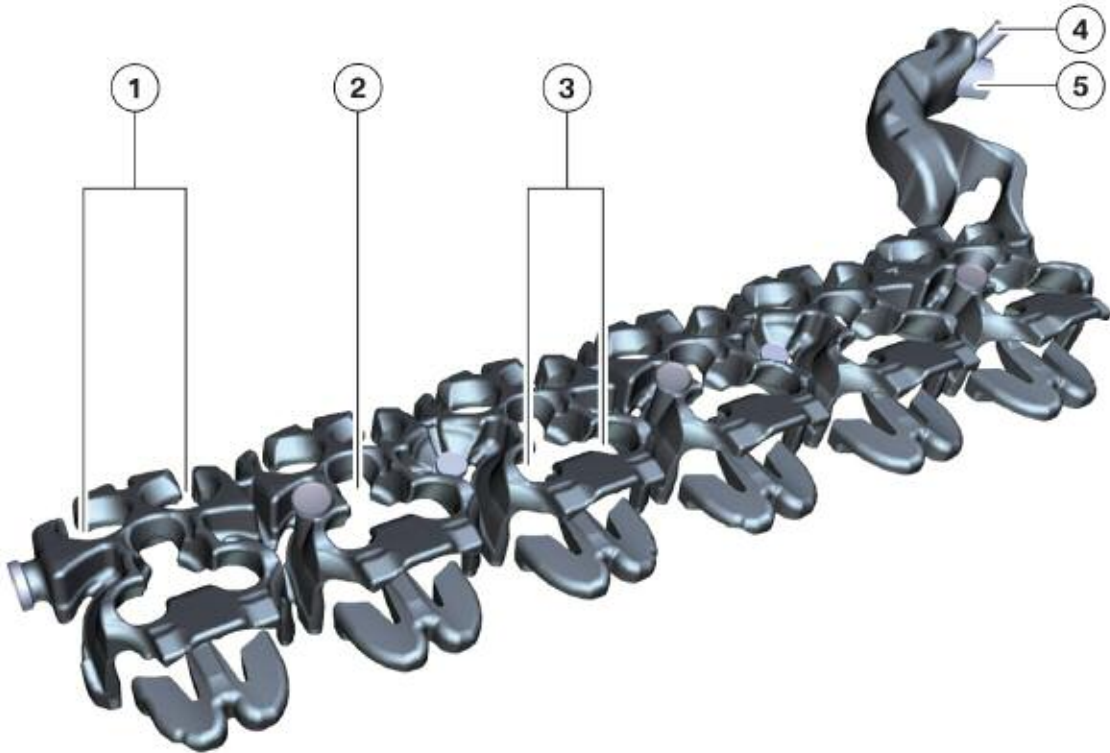

Index	Explanation
1	Channel, intake valves
2	Channel, fuel injectors
3	Channel, exhaust valves
4	Connection, coolant hose to thermostat (small cooling circuit)
5	Connection, coolant hose to radiator (large cooling circuit)

The cast iron cylinder liners are cast into the aluminum die-casting. The deck area (webs) between the cylinders have grooved coolant passages. Coolant can flow along these grooves from one side of the block to the other, thus cooling the deck area between the cylinders.

**N55, coolant passages and web cooling of the engine block**

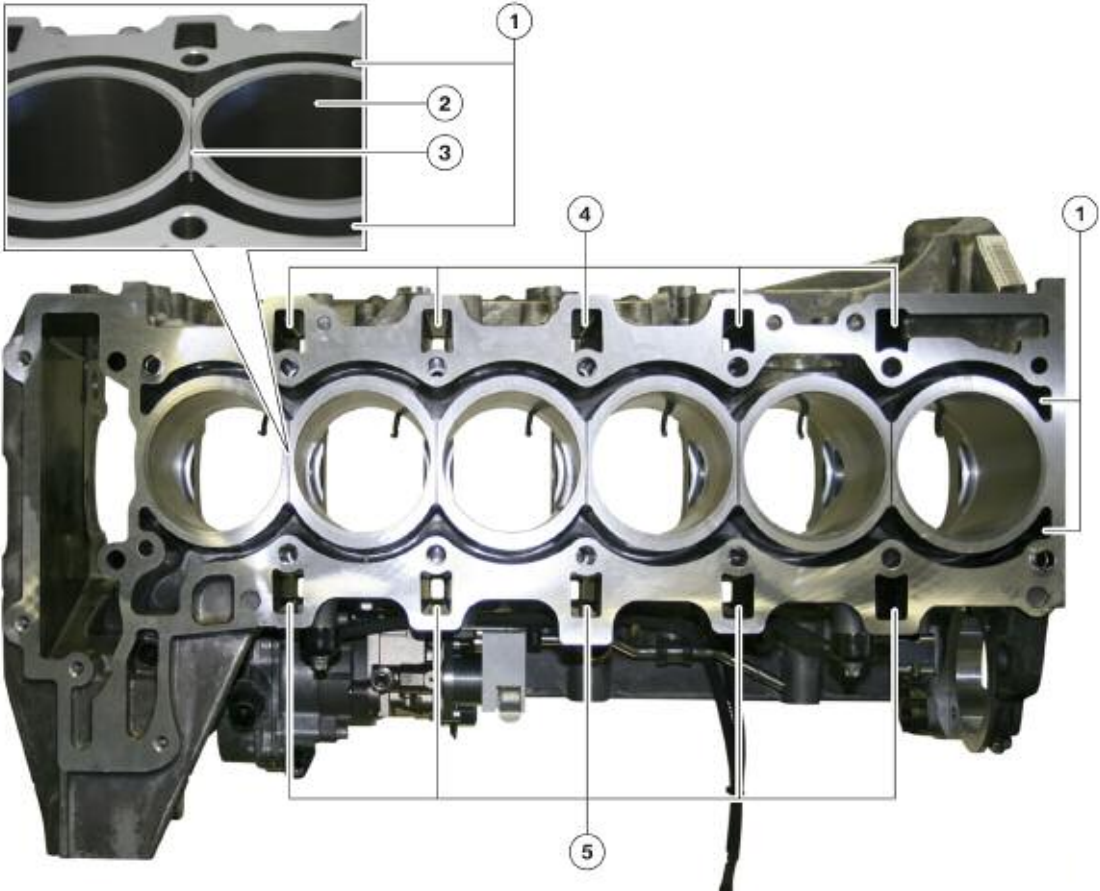

Index	Explanation
1	Cooling duct
2	Cylinder liner
3	Grooved coolant passage
4	Oil return ducts, exhaust side
5	Oil return ducts, intake side

## Service Information

### Cylinder Head

The combination of exhaust turbocharger, VALVETRONIC, and direct fuel injection is referred to as Turbo-VALVETRONIC-Direct-Injection (TVDI).

### Cylinder Head Cover

**If a customer complains about high oil consumption and oil is discovered in the turbocharger, it should not be immediately assumed that the turbocharger is defective.**



**If the oil is present in the fresh air pipe after the introduction of the blow-by gasses then the entire engine should be checked for leaks. Defective gaskets or crankshaft seals may be the cause of excessively high blow-by gas output.**

### Fuel Injectors

In order to remove the N55 fuel injectors from the cylinder head, special tool #13 0 270 must be utilized. Failure to use the special tool will result in damage to the injectors.

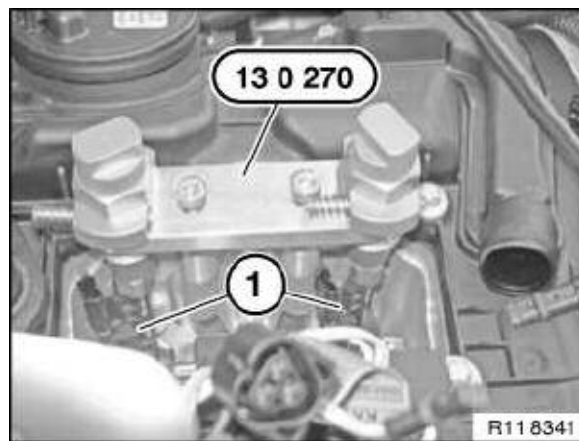
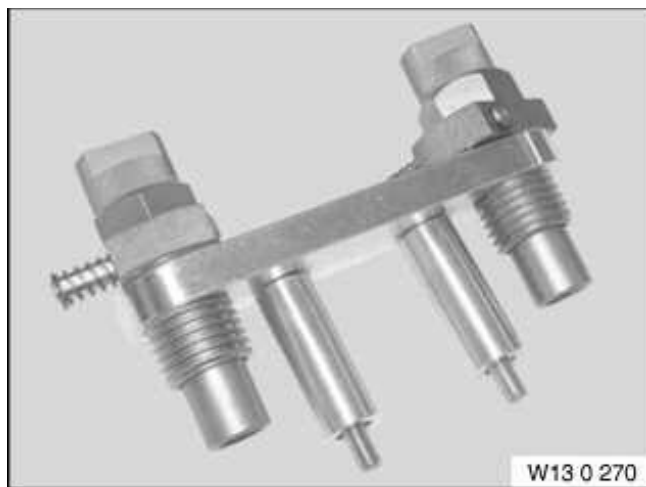

**Do not open the high pressure fuel injection system if the coolant temperature is above 40°C . The residual pressure in the high pressure fuel system could cause bodily injury.**



**It is essential to follow the repair instructions and observe the utmost cleanliness when working on the high pressure fuel system. Even minute soiling or damage at the connections of the high pressure lines and cause leaks.**

There is a new tool # 13 0 280 that must be used when replacing the PTFE seals on the tips of the solenoid valve injectors. As with piezoelectric injectors these seals must be replaced if and when the injectors are being re-installed.

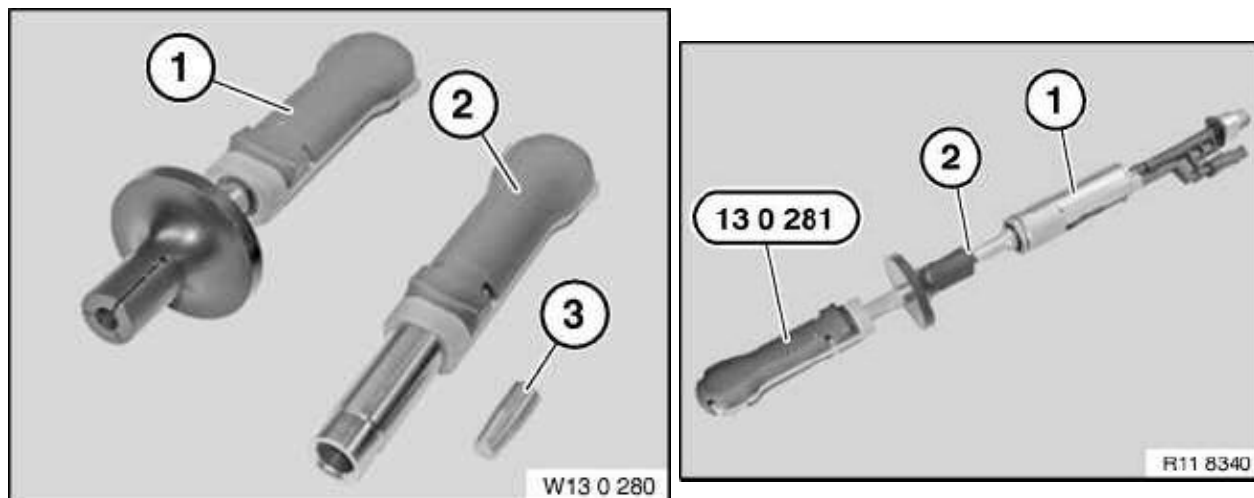

## Ignition Coils

The ignition coils of the N55 have been redesigned for better rigidity and durability. Particular care must be taken when working on the fuel system to ensure that the ignition coils are not wet with fuel. The resistance of the silicone material is greatly reduced by contact with fuel. This could compromise the coils insulation and result in arcking at the top of the spark plug causing a misfire.

- The ignition coils must be removed before working on the fuel system.
- When installing new solenoid valve fuel injectors utmost cleanliness must be observed.
- After removing the ignition coils use a rag to prevent fuel from entering the spark plug well.
- Ignition coils that have been saturated with fuel must be replaced.